

**Assembly and Operation
Instruction Manual**

**JOHNSON VIKING
VFO**



E. F. JOHNSON COMPANY
WASECA, MINNESOTA, U. S. A.



STANDARD WARRANTY

Adopted and Recommended by the Electronic Industries Association

The E. F. Johnson Company warrants each new radio product manufactured by it to be free from defective material and workmanship and agrees to remedy any such defect or to furnish a new part, except for electron tubes, in exchange for any part of any unit of its manufacture which under normal installation, use and service disclosed such defect, provided the unit is delivered by the owner to us or to our authorized distributor from whom purchased, intact, for our examination, with all transportation charges prepaid to our factory (return transportation charges also to be paid by owner) within ninety days from the date of sale to original purchaser and provided that such examination discloses, in our judgment, that it is thus defective.

This warranty does not extend to any of our radio products which have been subjected to misuse, neglect, accident, incorrect wiring not our own, improper installation, use of acid core solder, unauthorized modifications, or to use in violation of instructions furnished by us, nor extend to units which have been repaired or altered outside of our factory, nor to cases where the serial number thereof has been removed, defaced or changed, nor to accessories used therewith not of our own manufacture, nor to electron tubes.

The Radio Parts Distributor will assume the responsibility for replacement or exchange of any component part of a unit approved for remedy or exchange hereunder, through the factory Customer Service Department, without charge to the owner.

Defective electron tubes and executed service reports, carefully packed, should be returned prepaid directly to the tube manufacturer for adjustment at the following addresses. Ship power tubes via Railway Express.

NOTE: Tubes marked "E. F. Johnson Co.," regardless of manufacturer should be returned to E. F. Johnson Co. Waseca, Minnesota.

(a) RCA tubes to: Adjustment Service, RCA at the nearest of the following addresses:

34 Exchange Place Jersey City 2, N. J.	3601 South Adams St. Marion, Indiana	6355 East Washington Blvd. Los Angeles 22, California
---	---	--

(b) General Electric tubes to:
Adjustment Service
Owensboro Tube Works
General Electric Co.
Owensboro, Kentucky

(c) Amperex tubes to:
Amperex Electronic Corp.
230 Duffey Avenue
Hickville, Long Island
New York

(d) Eimac tubes to:
Eitel-McCullough, Inc.
San Bruno,
California

(e) Sylvania tubes to:
Sylvania Electric Products
Dept. EFJ
2001 North Cornell
Melrose Park, Illinois

(f) Penta tubes to:
Penta Laboratories, Inc.
312 North Nopal Street
Santa Barbara, California

This warranty is in lieu of all other warranties expressed or implied and no representative or person is authorized to assume for us any other liability in connection with the sale of our radio products.

Introduction to the

JOHNSON VIKING MODEL 122 Variable Frequency Oscillator Assembly, calibrating, and Operating Instructions

Good workmanship and careful adherence to instructions are necessary in the building and operating of the Model 122 Variable Frequency Oscillator. Although the design of this VFO was carried out with the objective of reducing the number of critical circuits to a minimum and making assembly simple, the capacitor and inductor values of the tuned circuit components were necessarily chosen with a given parts layout; therefore, the builder should duplicate the layout shown in the illustrations and described in the text. Circuits should be checked against the schematic diagram during the several steps of assembly. Much time and effort may be saved by finding an error or deviation from the illustrated layout before the unit is completed.

The accuracy of frequency adjustments will be largely determined by the amateur's requirement and the standard he has available. The calibrating instructions should be understood before attempting to make initial frequency adjustment. After the frequency setting adjustments have been completed to the satisfaction of the user, there is little reason to expect much change with time; however, it is always wise to check the frequency calibration periodically if the VFO dial scale is depended upon for determining the frequency of the transmitter.

The Viking Model 122 VFO has only two controls. A little care in noting the position of the Bandswitch and the Tuning dial before completing transmitter tuning will assure the operator of a correct frequency indication. The operating instructions are very simple but important. Be certain they are understood before using the VFO.

WARNING

The Viking Model 122 VFO derives its power from the transmitter low voltage power supply or an auxiliary supply. The B+ source to the VFO must be off to remove the 250 to 300 volts from the VFO. The "plt off" position of the bandswitch does open the screen and plate circuits of the oscillator tube but the high voltage exists on other components.

CONTENTS

Viking Model 122 VFO Instruction Book

<u>Paragraph</u>		<u>Page</u>
A	Assembly	
1	Bottom Chassis	3
2	Condenser-terminal board	4
3	Top Chassis	6
4	Bandswitch, Cables and Plugs	7
5	Dial drive and panel index plate	9
6	Preliminary Check	9
7	Bottom and tilt stand	10
8	Chassis, cabinet and escutcheon	10
B	Frequency Calibration	
1	Standard signal generator, receiver and VFO setup for calibration	11
2	160, 80, 40 meter VFO scale calibration	12
3	40, 20, 15, 10 meter VFO scale calibration	12
4	15 and 11 meter index marking and 11 meter calibration	13
5	Use of transmitter crystal oscillator as a standard	13
6	Use of W W V signal for VFO calibration	15
7	Procedure if trimmer or padder range appears inadequate	15
C	Operation	
1	Operating characteristics and requirements	16
2	With Viking II Transmitter	17
3	Suggestions for use with other transmitters	17
D	Photos, Charts, and Schematic Diagram	
1	Figure 1a Chassis (bottom)	20
	1b Condenser Board (rear)	
	1c Condenser Board (front)	
2	Figure 2a Chassis (top)	21
	2b Cabinet (rear-chassis in)	
	2c Cabinet (top side-chassis in)	
3	Figure 3a Bottom chassis and tilt stand	22
	3b Tube socket connections	
	3c Resistor-condenser charts	
4	Figure 4 VFO Schematic Diagram	23
E	Parts List and Warranty	24

A. Assembly Instructions

1. Bottom chassis assembly. Do not solder any connections until instructed to do so. Refer to Figure 1a.
 - a. Mount X50, miniature 6AU6 oscillator socket. Use 3/16" 4-40 screws, inserting screw from the bottom of the chassis and securing the screw with a 4-40 nut over the socket shell lip above the chassis. Place a #4 shakeproof washer under each screw head and a #6 teardrop solder terminal under the mounting screw near the front of the chassis for ground connection. Pin 7 should be toward the rear of the chassis.
 - b. Mount X51, miniature OA2 regulator socket, as above with the #6 solder terminal toward the front and socket pin 7 toward the rear of the chassis.
 - c. Mount X52, five terminal strip. Use 1/4" 6-32 binding head screws with a single #6 solder terminal, and a #6 shakeproof washer under the front nut, and one #6 solder terminal, two #6 solder lugs (with wings), and a shakeproof washer under the rear nut.
 - d. Mount J50, key jack, in the middle hole on the rear of the chassis, using only a single 3/8" -32 nut without lockwasher. Orient the jack so that the ground sleeve terminal is nearest the chassis.
 - e. Using a stripped piece of black #20 wire, connect the center shield, pin 2, and pin 3 to the #6 teardrop terminal under the mounting screw of the 6AU6 socket X50.
 - f. Connect the center shield and pin 2 of the OA2 socket, X51, to the teardrop terminal under its mounting screw using the #20 stripped wire.
 - g. Connect the 1/2 watt 47,000 ohm resistor R50 between pins 1 and 2 of the 6AU6 socket X50.
 - h. Connect a .005 mfd. condenser C70 between pins 6 and 2 of the 6AU6 socket X50.
 - i. Connect the 470 ohm 1/2 watt resistor R53 between the first and second terminals from the front on terminal strip X52.
 - j. Connect a .005 mfd. condenser C68 between the #6 teardrop terminal under the front mounting nut and the second terminal from the front of X52.
 - k. Connect the 4700 ohm 1/2 watt resistor R52 between the third and fourth terminals from the front of X52.
 - l. Connect a 150 mmfd. NPO ceramic condenser C67 (bk-bn-gn-bn-or) between the rear and the second terminal from the rear of X52.
 - m. Connect the 22,000 ohm 1/2 watt resistor R54 between the rear terminal of X52 and one of the #6 teardrop terminals under the rear mounting nut of X52.
 - n. Mount the switch mounting bracket BKT53 with the lip toward the rear of the chassis. Use 1/4" 6-32 binding head screws, #6 shakeproof washers, and 6-32 nuts.
 - o. Place the switch SW50 on the bracket, guiding the shaft through the hole in the front of the chassis. Secure the switch to the bracket with the 3/8-32 nut and shakeproof washer furnished. The switch should be positioned so the index ball will be on the right when the chassis is viewed from the bottom and front.
 - p. Mount the output coil L51 over the hole provided near the middle of the chassis. The coil should be placed so that the tapped portion with the lesser number of turns is toward the

1. p. chassis and terminated pins are toward the rear of the chassis. Insert the 1-3/4" 6-32 screw from the top of the chassis, running it through the coil form and securing the coil form with the small rectangular piece BKT55, a #6 shakeproof washer and a 6-32 nut. Be careful to center the coil so that the 1-3/4" 6-32 screw does not touch the pins which project through the coil form.
- q. Using the #20 black plastic wire, connect the pin of the output coil near the chassis to pin 5 of the 6AU6 socket X50 and also to the second terminal from the rear of terminal strip X52. Solder all three terminals just connected.
- r. Looking at the bandswitch SW50 from the rear, call the top terminal to the left of the steatite wafer mounting screw number 1, the terminal in the counter-clockwise direction number 2 and so on through 12. Using a piece of #20 black plastic wire connect terminal 12 of SW50 to the middle tap of the output coil L51. Solder the connections.
- s. Connect terminal 11 of SW50 to the top pin of L51 and to the third terminal from the front of X52. Solder at the terminal strip only.
- t. Connect terminal 10 of SW50 to the second terminal from the front of the terminal strip X52. Solder both terminals.
- u. 1) Cut a 1-1/2" length of #20 black plastic wire. Strip both ends 1/4 inch. Connect one end to terminal 5, SW50. Do not solder. Connect the other end to terminal 7, SW50. Solder.
2) Cut a 2-1/2" length of black plastic wire. Strip both ends 1/4". Connect one end to terminal 5, SW50 and the other end to pin 7 of X50. Do not solder.
- v. Cut one lead of the 22 ohm 1/2 watt resistor R55 and one lead of the 43 mmfd. (bl-yl-or-bk-or) NPO condenser C66 to 3/8" lengths. Connect the 3/8" leads together by forming hooks on each, crimping the hooks together and soldering the hooked connection. Slip a 1" piece of black insulation (stripped from the #20 wire) over the free end of C66 and connect that end to terminal 2 of SW50. Connect the free end of R55 to pin 1 of the 6AU6 socket X50 after cutting the lead so that C66 and R55 can be placed directly in line between the tube socket and the switch terminal. Solder the two connections.
- w. 1) Looking at the jack from the rear, the terminals are numbered 1, 2, 3, clockwise, starting with the ground terminal (nearest chassis).
2) Connect one end of the R.F. choke L52 to terminal 3 of J50. Do not solder. Connect the other end of L52 to terminal 5 of SW50 using a short length of #20 wire. Solder.
- x. Connect a .005 mfd capacitor (C69) between terminals 1 and 3 of J50. Solder both terminals.
- y. Connect the 18,000 ohm 2 watt resistor R51 between terminal 11 of the bandswitch SW50 and pin 1 of the OA2 socket X51. Solder both terminals.
- z. Using a piece of #20 black plastic covered wire, connect pin 5 of the OA2 socket X51 and pin 6 of the 6AU6 socket X50. Solder these connections and all other connections which have not been previously soldered except those on bandswitch SW50.

2. Condenser-terminal board assembly

- a. Refer to Figure 1b. Connect a .001 mfd silver mica condenser C59 between pins 1 and 5 of the condenser-terminal board CH55. Note the board is oriented so that there are three trimmer condenser mounting holes on the right side and two on the left side. Loop the condenser leads over the terminal pins as near the board as convenient to allow room for other connections on the outside of the pins.

2. b. Connect another .001 mfd. silver mica condenser C60 between pins 5 and 7 in the same manner as in step 2a and solder both condensers lightly to hold them in place.
- c. Connect a .0005 mfd. silver mica condenser C56 between pins 4 and 6 as shown in Figure 1b in the same manner as in step 2a.
- d. Connect another .0005 mfd. silver mica condenser C58 between pins 6 and 8 as in step 2a. Solder C57 and C58 leads lightly.
- e. Turn the condenser-terminal board around to the position shown in Figure 1c. Mount the 40 meter padder condenser C54, the 15M11 miniature condenser whose rotor terminal is on the right side when the stator is up and viewed from the rear. Use the nut provided on the condenser bushing.

All following condenser descriptions are from the rear view of the condensers.

- f. Mount the 40 meter trimmer C52, the 9M11 miniature condenser with the stator terminal on top and the rotor terminal to the right, in the same manner as C54 was mounted.
- g. Mount the 11 meter adjusting trimmer C56, the 15M11 miniature condenser in the lower hole on the left side. The stator terminal should be down and the rotor terminal to the right.
- h. Mount 160 meter padder C61, the 30M8 miniature condenser, in the upper right hole, with the stator terminal on top and the rotor terminal to the left.
- i. Mount the 160 meter trimmer, C63, 15M11 miniature condenser, in the hole below C61, with the stator terminal on top and the rotor terminal to the left.
- j. Mount the dual stator tuning condenser C55 in the middle of the board as shown in Figure 1c. The threaded bushing should be secured to the board with a 3/8 - 32 hex nut. The stator terminals are on top and the rotor terminal is below the condenser. Be careful not to subject the condenser to undue strain at the bushing by dropping the assembly or applying force to the shaft.
- k. Attach two mounting brackets BKT52 to the front mounting posts of C55 using two 1/4" 6-32 screws and #6 shakeproof washers.
- l. Strip a piece of the black plastic #20 wire and connect the rotor terminal of C52 to the rotor terminal of C56 and the rotor terminal of C56 to pin 8 of the terminal board.
- m. Using #20 stripped wire, connect the rotor of C63 to pin 7 of the terminal board, connect pin 7 to the rotor terminal of the tuning condenser C55. and connect rotor terminal of C55 to pin 8 of the terminal board. Solder all connections of steps k and l, except the rotors of C63 and C52.
- n. Mount and connect the fixed 47 mmfd, N220 negative temperature coefficient, ceramic condenser C51 (yel-yel-vlt-bk-or) between the rotor terminal of C52 and pin 3 of the terminal board. Keep the leads straight and taut.
- o. Connect the 43 mmfd. NPO zero temperature coefficient, ceramic condenser C53 (bk-yel-or-bk-or) between the left stator terminal of C55 and pin 3 of the terminal board.
- p. Connect the 91 mmfd., N080 negative temperature coefficient, ceramic condenser C64 (rd-wt-bn-bk-or) between the rotor terminal of C63 and pin 2 of the terminal board.
- q. Connect the 140 mmfd., NPO zero temperature coefficient, ceramic condenser C62 (bk-bn-yel-bn-or) between the right stator terminal of the large tuning condenser C55 and pin 2 of

2. q. the terminal board.
- r. Using the stripped #20 wire, connect the stator of C52 to the stator of C54 and the stator of C54 to pin 3 of the terminal board. The wire should be formed to pass inside of the padding condenser C54 stator and clear the stator by at least 1/8 inch.
- s. As in previous step r connect the stator of C63 to the stator of C61 and the stator of C61 to pin 2 of the terminal board.
- t. Connect the rotor of C54 to the left stator terminal of C55 with a piece of stripped #20 wire.
- u. Connect the rotor of C61 to the right stator terminal of C55. Solder all connections which have not been previously soldered on the front side of the condenser board.
- v. Turn the condenser-terminal board around to the position shown in Figure 1b, strip the ends and attach the plastic covered connecting wires, soldering the connections as the leads are attached. Proceed in the following order:
 - 1) a 3" black lead to pin 8 of the terminal board
 - 2) a 7" green lead to pin 1
 - 3) a 6" red lead to pin 4
 - 4) a 6" yellow lead to pin 5
 - 5) a 5" brown lead to pin 6
 - 6) a 6" grey lead to pin 3
 - 7) a 4" blue lead to the stator terminal of C56 (Figure 1c)
- w. Twist the green and yellow leads together, training them downward and slightly to the right as shown in Figure 1b. Twist the red and brown leads together, training them downward slightly to the right.
- x. Bring the blue lead around the mounting board and twist it with the black lead as shown in Figure 1b.

3. Top Chassis Assembly

- a. Place a 9/16" OD rubber grommet in the 7/16" hole just behind the condenser mounting board position as shown in Figure 2a.
- b. Position the condenser mounting board assembly and place all of the wires through the grommet as shown in Figure 2a.
- c. Secure the condenser terminal board brackets and the front tuning condenser brackets to the chassis by means of 1/4" 6-32 screws, shakeproof washers and 6-32 nuts. Place a #6 tear-drop solder terminal under the nut near the grommet on the bottom side of the chassis.
- d. Place the 3/8-32 panel bearing through the large hole on the flat dial support bracket BKT54. Secure with a 3/8-32 nut. Position BKT54 by slipping the bearing with the threaded end toward the rear, over the shaft of the tuning condenser C55. Secure BKT54 to the chassis with three 1/4" 6-32 screws, 6-32 nuts, and #6 shakeproof washers. Center the bracket and mounting board assembly and tighten all mounting screws and nuts.
- e. Place the dual oscillator coil L50 on the chassis directly to the rear of the condenser mounting board. The leads of the coil should be toward the front of the chassis and the spade studs should fall into the diagonally located holes on the chassis. Secure the coil with 6-32 nuts and shakeproof washers.
- f. Connect the leads of the coil to the pins of the condenser-terminal board as directly as

3. f. possible while clearing other leads and pins. Make connections as follows:
- 1) Bottom lead of lower coil to pin 1 of condenser board.
(Refer to Figures 1b and 2a). Solder.
 - 2) Top lead of lower coil to pin 2. Solder.
 - 3) Bottom lead of upper coil to pin 4. Solder.
 - 4) Top lead of upper coil to pin 3. Solder.
- g. Mount and secure the rear trimmer coupling support bracket BKT50 at the rear of the chassis in position so that the large holes are in line with the trimmer shafts. Secure with two 1/4" 6-32 screws, 6-32 nuts and shakeproof washer.
- h. Place the coil support bracket BKT51 assembly over the coil form with the yoke butt pieces separated so the butt pieces will fall over the coil form edge. Secure the brackets with a 3/16" 4-40 screw through the condenser mounting board CH55 and a 3/16" 4-40 screw and #4 shakeproof washer through the trimmer coupling support bracket BKT50. A shakeproof washer is not necessary against the phenolic board.
- i. Loosen the top screws on the coil support bracket BKT51 and force the butt pieces against the coil form. While holding these pieces against the coil form, tighten the top screws to secure the butt pieces firmly against the coil.
- j. Install an insulated coupling shaft assembly D53 shown in Figure 2a by placing the phenolic shaft through the rear coupling support bracket with the deep slotted end toward the trimmer condenser shaft. Place the engaging spring in the deep slot with the bowed end toward the condenser shaft so that the spring engages the condenser shaft slot and is compressed until the slots on the phenolic shaft straddle the rear coupling support bracket. Force a "C" washer over the slot of the phenolic shaft on each side of the bracket. Use long nose pliers to force the "C" washers on and close the opening somewhat if the "C" washer has been spread enough to make it possible to drop off the shaft. Repeat the coupling shaft installation procedure for the remainder of the coupling shafts.

4. Bandswitch, Cable, and Plug Connections.

- a. Refer to Figure 1a. Cut, strip ends, and connect the wires from the condenser mounting board to the bandswitch SW50. Refer to 1r for SW50 terminal numbering. Complete connections as follows:

- 1) Green to terminal 1
- 2) Yellow to terminal 4
- 3) Red to terminal 3
- 4) Brown to terminal 6
- 5) Blue to terminal 8
- 6) Gray to terminal 9
- 7) Black to the terminal under the nut of the condenser board mounting screw.

Solder all connections on SW50 and the ground terminal.

- b. RG59U and PL259 cable and plug assembly, G50 and PL50. The length of the coax cable G50 must be left at the length supplied as it is electrically part of the broadly tuned output circuit.
- 1) Cut and remove 1-1/4" of outer vinyl cover from one end of the RG59U cable.
 - 2) Push the UG176U adapter over the cable end with the threaded end first. Position the adapter to expose 1" of the copper braid beyond the adapter. If the adapter fits very tightly on the vinyl cover, reduce the diameter of the cover by filing or slicing the surface very thinly about 1/2" back with a sharp knife until the adapter slides over the cover.

4. b. 3) With the thin lip of the adapter 1" from the end of the cable, whose vinyl covering has been removed, comb the braid wires and lay them back evenly over the adapter lip. Cut off the excess braid strand length 3/8" back so that the braid strands do not reach the adapter threads.
- 4) Holding the adapter in place, cut and remove 9/16" of polyethylene insulation from the end, exposing the inner conductor.
- 5) Turn the outer knurled cylinder off of the coaxial plug PL259. Pass the inner plug part over the end of the cable, guiding the inside of the plug pin over the inner conductor. Turn the plug to engage the adapter UG176U threads and tighten the two parts together with gas pliers and vise or other suitable tool.
- 6) Solder the inner part of the plug to the braid wires and adapter at the cutaway section holes. Use a hot iron and run in a small amount of solder through each hole, flowing the solder over the braid wires.
- 7) Solder the inner conductor to the tip of the pin and cut off the excess inner conductor.
- 8) Screw the outer PL259 cylinder over the plug inner piece.

c. Three conductor cable and octal connector assembly G51 and PL51.

- 1) Remove the shell from the 8 prong plug PL51 by prying with a screw driver.
- 2) Remove the outer covering and unbraided 1-1/2" of shield braid on one end of the 3/c cable. Divide the loose shield strands in two parts and twist the strands of each part together. Strip 1/2" of insulation off each of the three conductors.

Insert the twisted braid conductors in pins 1 and 2 of the plug, pull through the pins 1/4" and solder. Insert and solder each of the three conductors to pins of the plug, allowing each to extend 1/16" beyond the pin end as follows:

- 1) Black tracer to pin 8
- 2) White tracer to pin 7
- 3) Red tracer to pin 3
- 4) Trim excess wire off all pins when the connections to the pins have been completed.

Place the plug shell over the cable and secure it to the plug proper.

- d. Place 9/16" rubber grommets in the two remaining 7/16" holes at the rear of the chassis.
- e. Remove the outer cover and comb out the braid on 6" of the free end of the 3/c cable. Cut off all but 1" of the braid and twist the remaining part together tightly. Insert the free end of the cable through the rear inner 7/16" grommets hole of the chassis, as shown in Figure 1a, and place the twisted braid wire in one of the #6 soldering lugs under the rear mounting nut of terminal strip X52. Crimp the lug over the shield wire and solder. The lug should be positioned to take the strain of the cable.
- f. Cut to length and connect the black tracer lead to terminal 2 of J50. Solder. Connect the white tracer lead to pin 4 of the 6AU6 socket X50. Solder. Connect the red tracer to the front terminal of X52. Solder.
- g. Remove the vinyl cover and comb out 1-1/4" of shield braid on the unconnected end of the RG59U cable G50. Cut 1/2" off the braid wires and twist them together tightly. Remove 3/8" of polyethylene from the end of the cable exposing the inner conductor.

4. h. Insert the cable through the outer grommited hole of the chassis as shown in Figure 1a and place the twisted shield wire in the remaining #6 soldering lug under the rear mounting screw of X52. Crimp and solder the lug to the shield wire. The lug should take most of the cable strain.
- i. Connect the inner conductor of the RG59U to the rear terminal of the terminal strip X52. Solder.
5. Dial Drive Assembly D51. Refer to Figures 1a and 2a.
 - a. Place the bearing and shaft assembly through the remaining 7/16" hole in the front of the chassis, the long shaft end extending out and the bearing threads into the chassis. Fasten with a 3/8-32 nut.
 - b. With the hubs toward the chassis, push the friction drive wheel and the drive disc on the chassis shaft and tuning condenser C55 shaft at the same time. The large friction disc should be engaged by the twin drive wheel discs. Tighten the drive wheel setscrews in a position where the dial drive disc is not bent by the drive wheel when the outside of the drive disc dial mounting plate is even with the condenser shaft end. Tighten the drive disc setscrews to the condenser shaft temporarily, paying no attention to its position relative to the condenser rotor.
 - c. Attach the calibrated dial plate to the mounting plate with the three short flat head 6-32 screws, orienting the dial so that the 7.425 and 1.75 mc markings are on the same side of the shaft as the setscrews on the dial drive disc hub.
 - d. Assemble the index plate to the front panel. Do this with care to prevent scratching the panel. Place the two flat head 4-40 screws through the holes near the upper part of the window opening. Place two #8 washers over each screw at the rear of the panel to serve as a spacer. Place the index plate over the screws with the index marker toward the front and bottom of the panel. Secure the index plate in its maximum upward position with two 4-40 nuts and lockwashers.
6. Preliminary Tests and Checkout.
 - a. Look over the entire completed assembly at this time, checking for unsoldered connections and loose nuts or screws. Make a thorough examination of all connections and check back on the assembly instructions if some connection appears to be incorrect.
 - b. Plug in the 6AU6 and OA2 tubes in their respective sockets. Place a shield can over the 6AU6 tube. Make the following tests before the panel and cabinet are assembled.
 - c. Attach the VFO knobs to their shafts temporarily. Turn the bandswitch to the counter-clockwise position (plt off).
 - d. Plug the power supply octal connector PL51 into the transmitter VFO supply socket or the socket on an auxiliary power supply. Turn on the transmitter low voltage or auxiliary power supply switch after making certain the "drive" control to the final tube of the transmitter is set at its minimum value. Check the lighting of the 6AU6 tube filament. The OA2 should have no glow.
 - e. Turn the bandswitch to the next position clockwise (160 80 40). The OA2 tube should now have a violet glow between its electrodes.
 - f. Attach a short antenna wire 1-1/2 to 2 feet long to the output coax plug PL50. Set up a receiver, whose calibration is correct within 25KC on the 160 meter band and 50KC on the 40 meter band, 5 to 25 feet from the VFO.

6. g. Turn all trimmers and padders to their half value position and set the main tuning condenser C55 so that the rotor plates are completely engaged with the smaller stator section. With no key in the VFO or transmitter, or with the key closed, a VFO signal should be heard in the receiver (Beat frequency oscillator on) around 1.95 to 2.05 mc. It may be possible to pick up a weaker image signal 900 KC from the wanted signal but it should be ignored in all cases. Harmonics of the 1.95 to 2.05 mc. signal may be used if the receiver cannot tune the 160 meter range.
- h. Turn the main tuning condenser to engage the large stator completely. Turn the bandswitch to the next position clockwise (40 20 15 10). A signal should now be heard from 7.35 to 7.7 mc. Ignore the image signal as before.
- i. Leaving the main tuning condenser in the position of step h, turn the bandswitch to the maximum clockwise position 11 (11 meter). A signal should now be found between 6.8 and 7.3 mc.

If no signal is found near the ranges indicated in any of the previous steps, first couple the receiver to the VFO closer than before and try again. If no signal is heard or the signals are out of the ranges, check all the condenser values and the condenser-coil connections on the condenser board with earlier instructions and the schematic diagram. Check the bandswitch connections with the instructions and the schematic diagram.

- j. Remove the short VFO antenna from the output plug and plug the PL259 RF plug into the transmitter VFO receptacle. Turn the transmitter crystal selector to the VFO input position and check the VFO for sufficient transmitter drive on all bands. If insufficient VFO output signal is noted, check the output coil L51, bandswitch, and terminal board X52 connections. It should be kept in mind that the transmitter must be capable of being driven by 5.5 volts or less on bands utilizing the 160 meter VFO output and 8 volts or less on bands utilizing the 40 meter VFO output; also, that the output circuit of the VFO includes the input circuit of the transmitter. The total input circuit of the transmitter at the VFO output plug PL259 should have a capacity of approximately 35 mmf (one foot of RG59U cable is 22 mmfd.) and a shunt resistance of 20,000 ohms or higher. Refer to Operating Instructions, part C, for a discussion of the VFO output characteristics.
7. Bottom, Rubber Bumper, and Tilt Stand Assembly. Refer to Figure 3a.
 - a. With the lip of the bottom cabinet piece oriented downward and forward, fasten the two rear bumpers G54 with 3/8" x 6-32 screws, flat washers, #6 shakeproof washers and 6-32 nuts.
 - b. Place the front rubber mounting feet over the tilt stand mounting brackets BKT56 as shown in Figure 3a and secure to the cabinet bottom with 3/8" 6-32 screws, flat and lockwashers, and 6-32 nuts. Before tightening the nuts, slip the tilt stand in place under the curved ends of the brackets with the tilt stand inner ends extending out from the surface of the bottom plate. Now tighten the 6-32 nuts while holding the tilt stand and tilt stand brackets in place. Try the tilt stand action by moving it upward through an arc of 100 degrees. The tilt stand should not move beyond that position. Return the tilt stand to its former position against the bottom piece.
8. Chassis, Cabinet, and Escutcheon Assembly. Marring and scratching of the painted surfaces of the panel and cabinet by screw driver slippage can be avoided by placing a piece of cardboard with a hole slightly larger than the screw head over the screw head while driving the screws in the following steps.
 - a. Remove the knobs from the chassis shafts and slide the front panel over the shafts in the position it will be finally mounted. This step will serve to check shaft alignment without placing the chassis in the cabinet. Note any binding or strain and adjust the drive shaft bushing or bandswitch bracket to correct any poor alignment which may be indicated. Lightly oil the control shafts (where they will pass through the panel) and the tuning shaft

8. a. bushing-bearing.
- b. Place the cabinet bottom piece CH51 over the cabinet lower lips. The orientation of the cabinet sides and back can be determined from Figure 2b. Attach the bottom piece to the sides with four #4 sheet metal screws and #4 shakeproof washers. Place the washers under the screw heads. Do not tighten screws completely but allow some shifting of the bottom for final alignment. The shakeproof washers will assure good electrical contact.
- c. Place the plugs and cables of the chassis through the large hole in the back of the cabinet, locate the chassis in the cabinet and turn a 3/8-32 nut on the 3/8 key jack bushing. Tighten with fingers only. Allow the nut on the chassis to act as a spacer between the cabinet and chassis. Attach the front of the chassis to the bottom piece with two #4 sheet metal screws and #4 shakeproof washers. Attach the rear of the bottom piece to the cabinet with two #4 sheet metal screws and #4 shakeproof washers, keeping the screws in front of the rear chassis edge. Do not tighten any of the screws completely.
- d. Attach the front panel to the cabinet and bottom piece with six #4 sheet metal screws and shakeproof washers. Be careful not to mar the panel or dial plate in this step. Do not tighten screws completely until other screws have been tightened and the top piece has been fitted to assure that the screw holes line up satisfactorily when it is finally secured to the cabinet. Do not secure the top to the cabinet at this time but line up the holes while tightening the bottom screws, chassis screws, and panel screws in the order listed.
- e. Loosen the index plate screws and move the index plate so that a 1/32" gap exists between the convex surface of the index plate and the dial edge.
- f. Loosen the main dial hub and move the dial until the dial marking between the 7.425 and 1.75 mc markings is in line with the index plate mark when the main tuning condenser C55 rotor plates are completely meshed with the large stator. Although the dial mark is below the dial edge, this setting should be made carefully and checked with the dial mark 180 degrees away which corresponds to the rear rotor plates being completely meshed with the small stator. The dial hub setscrew should be tightened in position with the dial plate front surface approximately 1/32" back of the index plate front surface. In most cases the dial position relative to the condenser shaft will not require further change. The calibrating instructions include procedures for making the change if it is necessary.

Attach the dial window escutcheon to the front panel with the two small 2-56 screws provided. The screw will self tap into the aluminum. Do not tighten the screw too hard; the self tapped threads may strip. The wide side of the escutcheon should be at the lower edge of the dial window.

- g. Attach the knobs to the shafts. Space the back of the knobs 1/8" from the panel. Tighten the tuning knob setscrew while the knob mark is in any position relative to the shaft rotation. Turn the bandswitch shaft to its maximum counter-clockwise position and locate the bandswitch knob on the shaft so that the marker lines up with the "plt off" designation. Tighten the knob setscrew securing the knob in this position. Attach VFO cover using six #4 sheet metal screws and shakeproof washers. If shaft binding is noted, remove the bottom piece and realign the tuning shaft bushing to relieve the binding.

B. Frequency Adjustment and Calibration

1. Signal generator, receiver, and VFO setup for the Viking Model 122 VFO calibration.
 - a. The accuracy of the Viking Model 122 VFO will be no better than that of the signal generator used to calibrate it. To fully utilize the stability and calibration capabilities of the Viking Model 122 VFO, the frequency standard used to calibrate it should have an accuracy of .005% or better. Most crystal standards or crystal calibrated variable frequency standards are satisfactory for normal calibration purposes. A moderate signal output, capable

1. a. of being easily detected by the receiver which will be used for zero beat indication, is necessary at the following frequencies:

F1a Any given frequency (preferably a VFO low frequency scale mark frequency) between 1.75 to 1.78 mc or any of the first eight harmonics of 1.75 to 1.78 mc in the range of the receiver. 1.76, 3.52, 5.28, 7.04, and 8.80 mc are examples of crystal frequency possibilities.

F2a Any given frequency (preferably a VFO low frequency scale mark frequency) between 1.96 and 2.00 mc or any of the first eight harmonics of 1.96 to 2.00 mc in the range of the receiver.

F3a Any given frequency (preferably a VFO high frequency scale mark frequency) between 7.00 and 7.07 mc or any of the first four harmonics of 7.00 to 7.07 mc in the range of the receiver.

F4a Any given frequency (preferably a VFO high frequency scale mark frequency), between 7.35 and 7.425 or any of the first four harmonics of 7.35 to 7.425 mc.

Warm up the signal generator for at least 1/2 hour or as long as suggested by the signal generator instructions before using it for VFO calibration.

- b. Set up a receiver capable of detecting each of the frequencies chosen in 1a. Attach antenna leads to the receiver input and the signal generator output and bring the leads together until signal generator output can be picked up by the receiver. Separate and shorten the leads as found necessary to keep the receiver from blocking due to excessive signal input. Allow the receiver to warm up for about 1/2 hour, to stabilize the local oscillator, and log dial settings for frequencies F1a, F2a, F3a and F4a. The beat frequency oscillator in the receiver may be used to log and compare the signal generator and VFO frequencies but it is desirable to obtain the final zero beat indications between the VFO and signal generator signals without the beat frequency oscillator. Avoid setting the receiver on or logging image frequencies.
- c. Warm up the Viking Model 122 VFO for 1/2 hour with the bandswitch in the 160 80 40 position. Attach an antenna lead to the output coax plug pin and bring the lead near the receiver antenna. Turn the VFO dial to the frequency F1, between 1.75 and 1.78 mc. chosen as the low 160 meter calibrating point, and find it or its harmonic (near F1a) on the receiver. Note how close the VFO calibration is initially. Repeat the same procedure at the high 160 meter calibrating point and the 40 meter high and low points after moving the bandswitch to the 40 20 15 10 position.

2. 160, 80, 40 Meter VFO Scale Calibration

- a. Set the VFO bandswitch on the 160 80 40 position and the dial at F2, the frequency between 1.96 and 2.00 mc chosen for the high 160 meter calibrating point. Set the signal generator and the receiver at F2a. Adjust the "160 hi" trimmer at the rear of the VFO (refer to Figure 2b) until the VFO zero beats with the signal generator.
- b. Turn the VFO to F1, the receiver to F1a, the signal generator to F1a and adjust the "160 lo" padder until the VFO zero beats with the signal generator.
- c. Repeat the "160 hi" and "160 lo" adjustment, zero beating the signal generator and VFO as accurately as the ability to reset the two units warrants.

3. 40, 20, 15, 10 Meter VFO Scale Calibration

- a. Set the VFO bandswitch on the 40 20 15 10 position and the high frequency dial scale at F4, the frequency between 7.35 and 7.425 mc chosen for the high 40 meter calibration. Set the

3. a. signal generator and the receiver at F4a. Adjust the "40 hi" trimmer at the rear of the VFO until the VFO zero beats with the signal generator.
 - b. Turn the VFO to F3, the frequency between 7.00 and 7.07 mc chosen for the low 40 meter calibration, the receiver to F3a, the signal generator to F3a, and adjust the "40 lo" padder until the VFO zero beats with the signal generator.
 - c. Repeat the "40 hi" and "40 lo" adjustment, zero beating the VFO as accurately as the ability to reset the two units warrants.
4. 15 and 11 Meter Index Marking and 11 Meter Calibration
 - a. Set the VFO dial on the 7, 14, 28 mc mark. Place a light pencil mark or scratch on the escutcheon window starting at the lower inside edge in line with the 21 mc mark. Carefully remove the escutcheon window and make the mark deeper across the lower inside edge with a thin hacksaw blade or similar tool. If a more elaborate index marker is desired for the 15 and 11 meter band, a right angle piece of #24 or #22 wire, 1/8" on each leg, can be formed and cemented into the slot with the protruding leg on the inside edge extending toward the 21 mc mark when the escutcheon window is again replaced.
 - b. The 11 meter band VFO output is in the neighborhood of 6.75 mc. A given frequency, F5a, in the range 6.7 to 6.85 mc or any of the first four harmonics of the 6.7 to 6.85 mc range may be used to calibrate the 11 meter range. Turn the VFO bandswitch to the 11 meter position and set the dial scale of the 11 meter band on the standard frequency F5 or the harmonic of the standard signal which falls in the 11 meter band. Set the receiver to the 11 meter range or a subharmonic and detect the standard signal frequency. Adjust the "11 meter" trimmer until the VFO zero beats with the standard frequency.
 - c. Recheck the 40 20 15 10 calibration after the 11 meter adjustment. There is little likelihood that further readjustment is necessary unless a large change was required in the "11 meter" setting.
5. VFO Calibration Using the Transmitter Crystal Oscillator or Other Standard Signal Sources.
 - a. Crystals of known frequency and accuracy in the frequency ranges F1a, F2a, F3a, and F4a (designated in paragraph B1a) can be used in the transmitter crystal oscillator to provide standard frequency signals for the VFO calibration. The first stages of the transmitter must be arranged to allow the crystal oscillator to operate at the same time the VFO is operating. When the VFO is used with the Viking II transmitter, the phone cw switch is operating. When the VFO is used with the Viking II transmitter, the phone cw switch must be in the "cw" position, the crystal switch on the position of the desired crystal, and the keying circuit closed (the Viking II keying circuit is closed when no key plug has been inserted). If the signal from the transmitter oscillator cannot be detected by the receiver readily, an antenna lead may be added by placing one end of a two or three foot lead in the vicinity of the oscillator tank coil and bringing the other end outside of the transmitter cabinet. The crystal oscillator signal magnitude can also be built up by tuning the plate circuit of the crystal oscillator to the crystal frequency or its harmonics. The VFO frequency can now be compared to the crystal oscillator frequency and adjustments can be made according to the procedure previously outlined in B4.
 - b. An example of calibrating the VFO using actual crystal values may be helpful. Assume that the following crystals have been found as part of the amateur station equipment: 7060 KC, 3690 KC, and 1980 KC. The dial calibration points then become:

$$F1 = \frac{7.060}{4} = 1.765 \text{ mc}$$

$$F2 = 1.980 \times 1 = 1.980 \text{ mc}$$

5. b. $F3 = 7.060 \times 1 = 7.060 \text{ mc}$

$F4 = 3.690 \times 2 = 7.380 \text{ mc}$

The receiver setting and VFO harmonic which may be used for each respective dial calibration frequency becomes:

$F1a = 7.060 \times 1 = 7.060 \text{ mc}$

$F2a = 1.980 \times 4 = 7.920 \text{ mc}$

$F3a = 7.060 \times 1 = 7.060 \text{ mc}$

$F4a = 3.690 \times 2 = 7.380 \text{ mc}$

Proceed as follows:

- 1) Set the VFO bandswitch on 160 80 40 and the dial on the 1.980 mc mark. Zero beat the fourth harmonic of the VFO output with the fourth harmonic of the 1.980 mc crystal oscillator output by adjusting the "160 hi" trimmer.
 - 2) Set the VFO dial on the 1.765 mc mark and zero beat the fourth harmonic of the VFO signal with the 7.060 mc crystal oscillator signal by adjusting the "160 lo" padder. Repeat steps 1 and 2 to minimize adjustment interaction.
 - 3) Set the VFO bandswitch at 40 20 15 10 and the dial on the 7.38-29.250 mc high frequency scale mark. Zero beat the VFO signal with the second harmonic of the crystal oscillator signal by adjusting the 40 "hi trimmer".
 - 4) Set the VFO dial to the 7.060-28.240 mc mark. Zero beat the VFO signal with the crystal oscillator signal by adjusting the "40 lo" padder. Repeat steps 3 and 4 to minimize adjustment interaction.
 - 5) The 11 meter band setting may be made with a crystal which will place a harmonic signal in the 11 meter band. Assume a 1820 KC crystal is available. Set the VFO bandswitch on 11 and the dial on 27.3 mc (the 15th harmonic of 1.820 mc). Zero beat the fourth harmonic of the VFO to the 15th harmonic of the crystal oscillator with the "11 meter" trimmer. Make certain that the receiver is tuned to the correct harmonic before attempting to make the 11 meter setting.
- c. The user may think of several sources of standard signals other than those mentioned. In each case the accuracy of the source should be known before using it. Many combinations of harmonics can be found and no attempt has been made to cover all of them in this discussion. The beat frequency oscillator of the receiver can be used to "remember" a standard signal for a short time. The receiver must be thoroughly warmed up and operated with out excessive input signal to prevent local oscillator shift errors from being introduced. Other signal sources which may be used but not discussed are:

- 1) The signal of another amateur station whose frequency has been determined by a standard broadcast station.
- 2) The harmonics of a signal generator whose output signal has been zero beat with a broadcast station.
- 3) Signals of W W V discussed in the next topic.

The VFO user must adapt his techniques to the signal source he has available.

5. d. Band edge crystals or crystals near the usual operating frequencies of the amateur stations are always valuable for occasional monitoring of the VFO signals. They may be used in a separate oscillator circuit or the crystal oscillator stage of the transmitter.

6. VFO Calibration Using the W W V 10 mc signal. This calibration is not recommended if other standard signal sources are available. It will be noted that most calibration points are on the ends of the bands and the 40 20 15 10 band high scale calibration includes the tracking error of the low frequency 160 80 40 band. The receiver, the receiver BFO, and the VFO should be warmed up for 1/2 hour before calibrating.
 - a. 160, 80, 40 meter calibration.
 - 1) Zero beat the receiver BFO to the 10 mc W W V signal.
 - 2) Set VFO dial at 2.00 mc and the bandswitch on 160 80 40.
 - 3) Adjust the "160 hi" VFO trimmer until the fifth harmonic of the VFO is zero beat with the receiver BFO.
 - 4) Leaving the VFO at this setting, zero beat the receiver BFO with the seventh harmonic of the VFO (14 mc).
 - 5) Turn the VFO to 1.75 mc and adjust the "160 lo" VFO trimmer to zero beat the eighth harmonic of the VFO with the receiver BFO.
 - 6) Adjust both ends of the 160 80 40 bands to zero beat the eighth and seventh harmonics of the VFO with the receiver BFO as necessary.

 - b. 40, 20, 15, 10 meter calibration.
 - 1) Set the VFO dial at the 1.85 mc mark and zero beat the receiver BFO to the eighth harmonic of the VFO frequency at 14.8 mc.
 - 2) Set the VFO bandswitch to 40 20 15 10 and the dial to the 7.40-29.6 mc mark. Zero beat the second harmonic of the VFO to the 14.8 mc receiver of the VFO to the 14.8 mc receiver setting by adjusting the "40 hi" trimmer.
 - 3) Set the VFO bandswitch and dial for 1.75 mc output again and zero beat the receiver BFO at 14 mc. Set the VFO bandswitch and dial at the 40 20 15 10 band low frequency end (7.00, 14, 21 and 28 mc) and adjust the "40 lo" padder to zero beat the VFO second harmonic with the receiver 14.0 mc BFO setting.
 - 4) Repeat steps 1, 2 and 3 if greater accuracy is desired.

 - c. 11 meter calibration
 - 1) Set the VFO bandswitch and dial for 1.80 mc output.
 - 2) Tune the receiver to 27 mc and zero beat the receiver BFO to the 15th harmonic of the VFO.
 - 3) Set the VFO bandswitch on 11 and the dial on 27.0 mc. Adjust the "11 meter" trimmer to zero beat the fourth harmonic of the VFO to the receiver BFO setting.

7. Procedure if the VFO frequency cannot be adjusted to the dial markings due to apparent lack of trimmer or padder range.
 - a. Check to make certain the frequency standard used is accurate (crystals used in amateur service are often found to differ from their marked frequency due to holder conditions, oscillator circuit loading or non-critical original calibration).
 - b. Make certain image frequencies are not being mistaken for desired frequencies in the receiver.
 - c. If after checking the frequency standard and receiver settings, the VFO frequency cannot be adjusted to chosen dial marks, adjust the trimmers and padders to bring the VFO frequency as close as possible to the dial mark frequencies. Remove the VFO cover and recheck the dial location relative to the tuning condenser shaft according to paragraph A 8e.

7. c. If the dial requires relocating, try calibrating the VFO scale again, as directed in previous instructions, with the top off. If the calibration appears normal, replace the cover and recheck all calibration points with the cover on.
- d. Upon removal of the cover in step c, if the dial location is found to be correct, note the engagement of the trimmers and padders.
 - 1) If any padder or trimmer is fully engaged and all of the others are engaged 1/4 or more, loosen the dial hub setscrews and move the dial counter-clockwise with respect to the tuning condenser shaft (keeping the shaft stationary) an amount corresponding to 1/16" on its periphery.
 - 2) If any of the padders or trimmers is completely open, move the dial clockwise, with respect to the condenser shaft, an amount corresponding to 1/16" on the dial periphery
 - 3) If any of the trimmers or padders is closed and the corresponding trimmer or padder on the same band is open, add a 6.8 mmf ceramic NPO condenser (bk-bl-gy wt gn) (C50 or C65) across the closed padder or trimmer to extend its range.

If the VFO can now be tracked to the dial, replace the cover and complete calibration.

C. Operation

1. General Operating Characteristics and Requirements

- a. The Viking Model 122 VFO has been designed as a crystal substitute
The output of
 - a minimum of 8 volts r.m.s. across 25,000 ohms in the frequency range of 7.00 to 7.425 mc and
 - a minimum of 5.5 volts r.m.s. across 25,000 ohms in the frequency range of 1.75 to 2.00 mc
 may be applied across the crystal oscillator grid circuit of many transmitters directly, to take the place of 160 meter and 40 meter crystals normally used with the transmitters. A recommended basic transmitter first stage oscillator-amplifier circuit and a recommended booster amplifier will be discussed later for transmitters where more VFO isolation or output is required.
- b. The VFO has only two controls. It is imperative that the correct dial scale corresponding to the bandswitch position is at the index window when operating. The VFO will drive many transmitters on 40 meters in either 160 80 40 or 40 20 15 10 bandswitch positions. The 160 80 40 meter position is usually preferred for 40 meter operation because the chance of "straight through" feedback is eliminated. The bandswitch setting for all other bands should be on the indicated band. Suitable frequency multiplication must be provided in the transmitter exciter stages.
- c. The output circuit of the Viking Model 122 VFO is a broadly tuned circuit which depends on the output cable and the transmitter input capacity to some extent. It is therefore impossible to obtain full VFO output with a cable length, between the VFO and the transmitter, that differs markedly from that provided with the VFO. The transmitter total input capacity should be between 30 and 40 mmf to center the VFO maximum output in the VFO frequency ranges (the Viking II transmitter has a one foot length of RG59U, the VFO input jack, and the tube input capacity to make up approximately 30 mmf).
- d. Keying can be arranged so that the VFO is keyed by the transmitter keying circuit. Pin 8 of the VFO power plug carries the keying circuit. With such an arrangement the VFO **simpl** becomes a frequency determining device and normal operating techniques of crystal **trans-**mitter operation apply. If it is desired to key the transmitter stage alone while the VFO **is** allowed to operate continuously, a shorted plug should be plugged into the rear VFO key jack. If it is desired to key the VFO without keying the transmitter, simply remove the **key** plug from the transmitter and insert the key plug in the VFO keying jack.

1. e. When the transmitter is operated "straight through" with the VFO on 160 meters or 40 meters, avoid placing the VFO in a location where high output RF fields reach the VFO. Although the rather complete shielding on the VFO will keep the likelihood of frequency pulling to a minimum, the high sensitivity of the low level VFO oscillator circuit may make a very slight feedback troublesome.
- f. "Zero beating" receiver signals with the VFO may require the reduction of the transmitter exciter leakage to the receiver. Two ways to do this are:
 - 1) Disabling the first stage of the transmitter while the VFO is allowed to oscillate. The VFO-to-receiver signal may be fed out by a small auxiliary lead in the circuit of the VFO output at the transmitter.
 - 2) Disconnecting the VFO from the first stage of the transmitter by the crystal VFO selector switch. The sensitivity of the first transmitter stage may be so high that the switch terminal to terminal capacity may still couple enough VFO signal to the first stage to create a signal level in the receiver sufficient to mask the received signal. In this case, provision for attenuating the VFO signal at the first stage can be incorporated in the crystal VFO selector switch. The crystal positions 1 and 2 of the Viking II transmitter lend themselves nicely when resistors are placed between the outside jacks of the crystal positions and a chassis ground. The resistors thus shunt the grid of the input stage to ground when the crystal switch is put in the 1 or 2 positions. The value of the resistor can be adjusted to attenuate the signal to the degree desired.
- g. The power requirement of the Viking Model 122 VFO.

An auxiliary power supply or the low voltage power supply of the transmitter must be capable of supplying 250 to 300 volts of plus D.C. to chassis ground at 15 ma and 6.3 volts A.C. to chassis ground at .3 ampere. The 250 to 300 volt supply may be unregulated but it should not be subject to sudden voltage changes or excessive voltage change with a change of 5 to 10 ma current drain. An octal socket is a natural connecting device for the octal plug provided on the VFO.

2. Operation with the Viking II Transmitter. Most of the comments made under General Characteristics apply to the use of the VFO with the Viking II. A few details and suggestions are included to help the Viking II owner make his initial installation.
 - a. Plug the VFO power plug in the VFO socket in the left rear corner of the chassis. The VFO output coax plug should be plugged in the input receptacle below the fuse plug. Check both the RF input lead and VFO power lead for correctness of wiring, continuity and shorts if any difficulty arises in obtaining VFO drive.
 - b. The crystal selector of the Viking II must be in the "0" position for VFO operation. Band edge or other calibrating crystals may be placed in any crystal position and referred to simply by turning the crystal selector to the proper position.
 - c. The discussion of keying under general operating characteristics applies directly to the Viking II. When the Viking II is on "phone" the keying circuit is opened when the plate switch is turned off. If no plug has been inserted in the VFO the phone-cw switch must be placed on "cw" to close the VFO keying circuit when the plate switch is off. The method of checking the VFO frequency in the receiver is to turn the phone cw switch to "cw". If the exciter coupling to the receiver is too great, turn the crystal selector switch to an empty or shunted crystal position to reduce the signal as discussed in C1f.

3. Operation with Other Transmitters

In general the Viking Model 122 VFO output will be applied at the grid circuit of the crystal oscillator of a transmitter. Some considerations which must be made when the VFO is to be

3. used with a given transmitter are:

- a. Power supply for the VFO (discussed in C1g)
- b. The power sensitivity of the first stage of the transmitter. The voltage output of the VFO (listed in C1a) must be sufficient to drive the transmitter first stage to a value necessary for the required amplification or frequency multiplication.
- c. Sufficient isolation between the tuned tank circuit of the first transmitter stage and the VFO must be provided to prevent feedback effects when that tank circuit is tuned to the VFO frequency.
- d. Some triode oscillator and tri-tet oscillator stages will not provide sufficient isolation or sensitivity to be used directly with the VFO. A suggested transmitter crystal oscillator-amplifier circuit is shown below. This circuit properly built will provide the first stage sensitivity and power output required for many transmitters.

A 6AU6 tube will provide sufficient isolation, sensitivity, and an output of more than one watt on "straight through" operation and somewhat less as a frequency doubler if proper tank constants are provided. A 6AG7 tube may be used if more power output is required. A 6AG7 can be expected to provide two or three times as much power output as the 6AU6 as an amplifier or frequency doubler. Tubes with higher plate to grid capacity may give feedback troubles. Reasonable circuit layout and good separation of grid and plate circuit components in this stage is desirable. The 6AG7 power requirement is somewhat greater than that of the 6AU6.

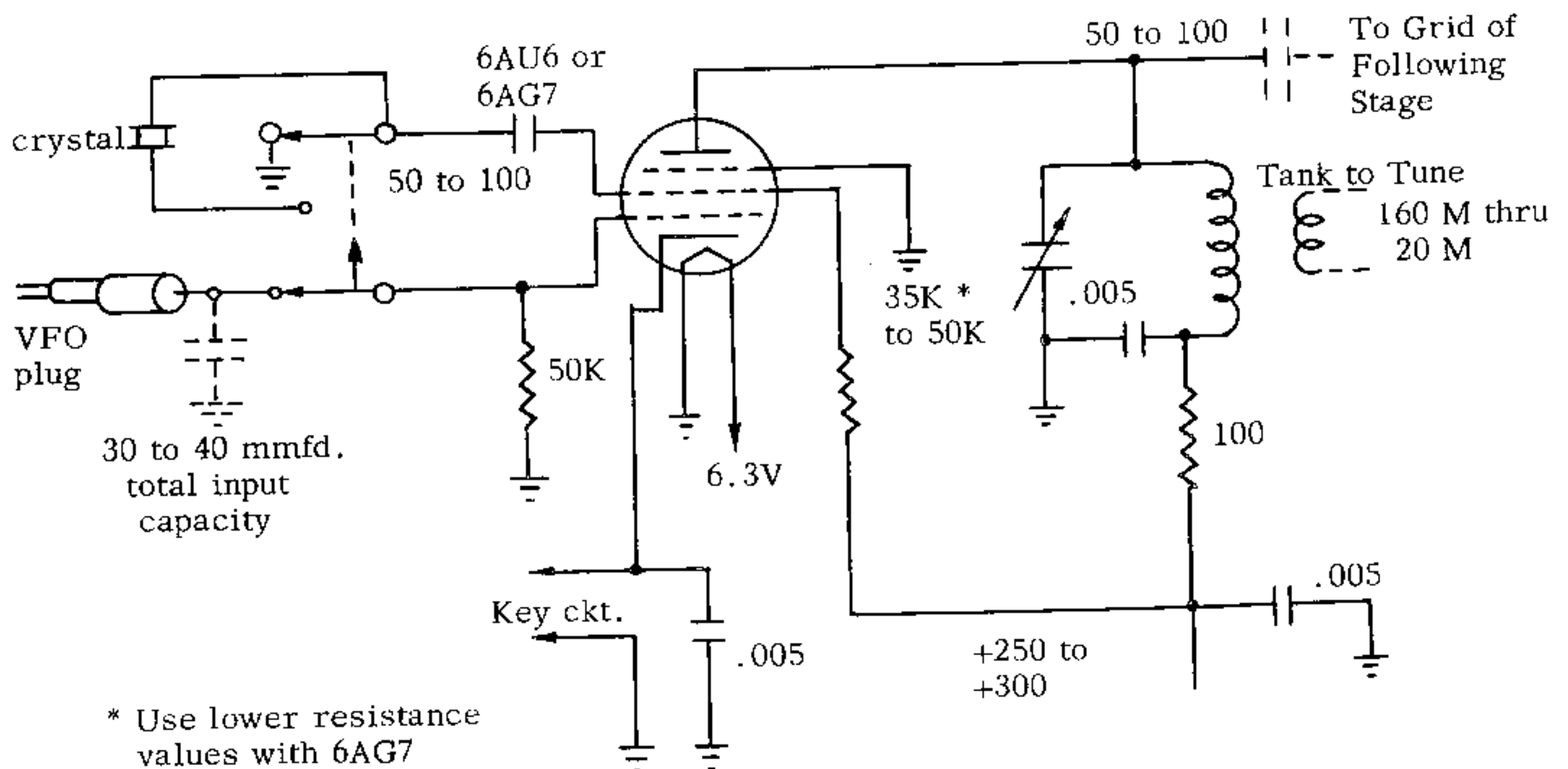

- e. If 25 to 30 volts of RF at the VFO frequency ranges will drive the transmitter, an amplifier stage can be added at the transmitter. The amplifier may be directly coupled to the transmitter input circuit. The circuit below will provide 25 to 50 volts across 10,000 ohms without adding tuning controls. The 6AG7 tube can be expected to have an output of 40 to 50 volts while the 6AU6 can be expected to have an output of 20 to 30 volts RF. The amplifier should be located near the input stage of the transmitter. No capacity should be added in the plate circuit of the amplifier other than the output capacity of the amplifier tube and the input grid of the tube being driven by the amplifier. A suggested circuit is shown on the next page:

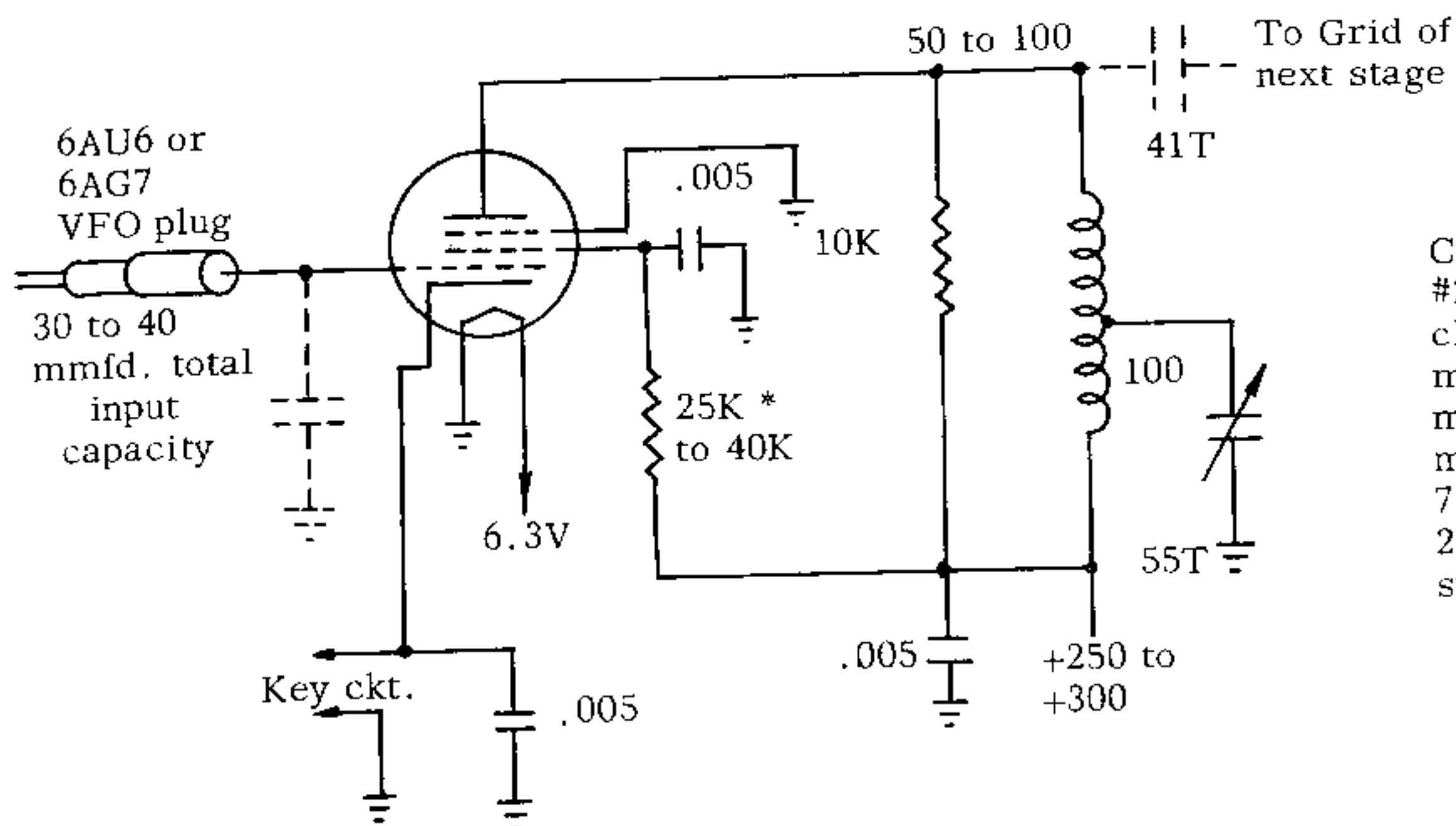

Coil on 1" form
#24 enamelled wire
close wound. 100
mmf. condenser
may be adjusted for
maximum output at
7.2 mc on the 40,
20, 15, 10 VFO
switch position.

* Use the lower resistance values with the 6AG7

3. e. The power supply of the transmitter should be capable of supplying the power required by the tube (250 to 300 VDC at 13 ma, 6.3V at .3A for the 6AU6, and 250 to 300 VDC at 25 ma, 6.3V at .65A for the 6AG7).
- f. The output circuit of the Viking Model 122 VFO has a D.C. resistance of 22,000 ohms. The output circuit of the VFO must be isolated from the transmitter input grid by a blocking condenser (100 mmf) unless the 22,000 ohm grid resistance is not too low for the input stage.
- g. Undoubtedly many existing transmitters can be connected directly or readily adapted to the Viking Model 122 VFO without much effort. It is recommended that parts C1 and C3 of these instructions and the transmitter under consideration be studied before proceeding to connect the VFO to a transmitter. Temporary connections and trials should be made before changing or adding circuits. Permanent arrangements can be made after the transmitter circuits have been found to utilize the VFO as the user desires.

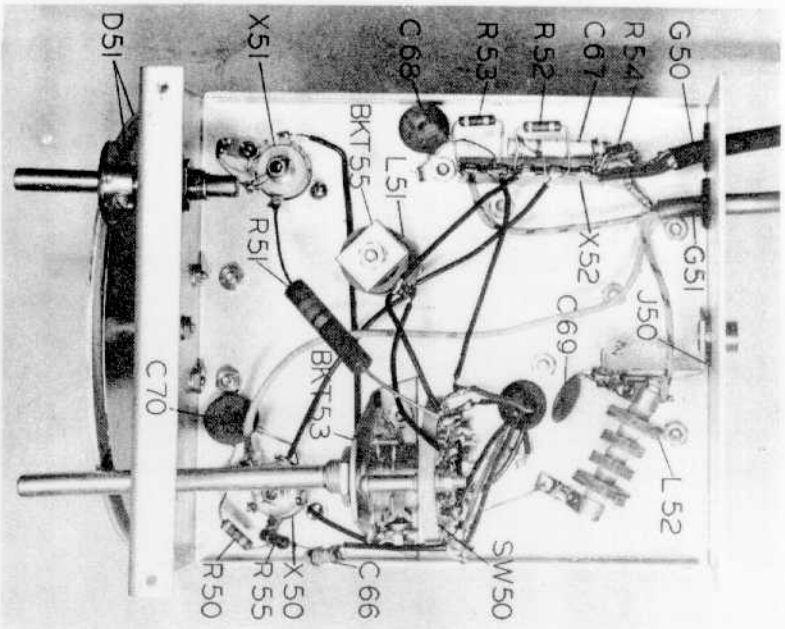

FIGURE 1a
CHASSIS BOTTOM

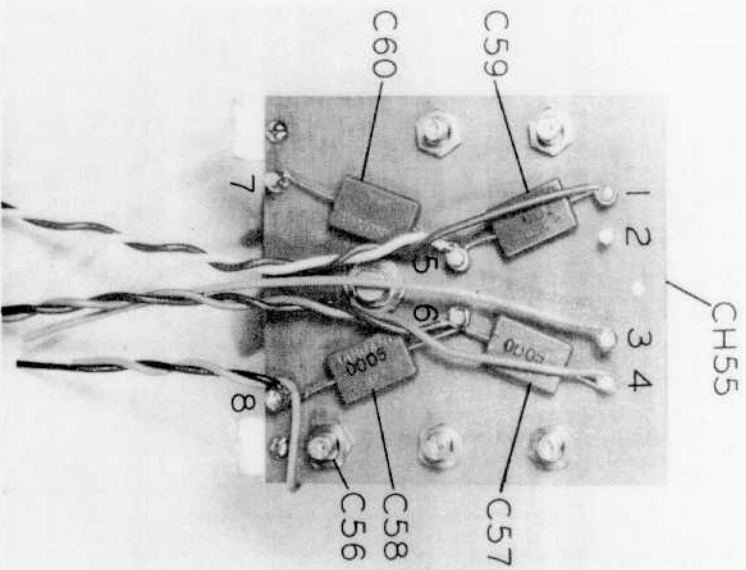

FIGURE 1b
REAR CONDENSER
TERMINAL BOARD

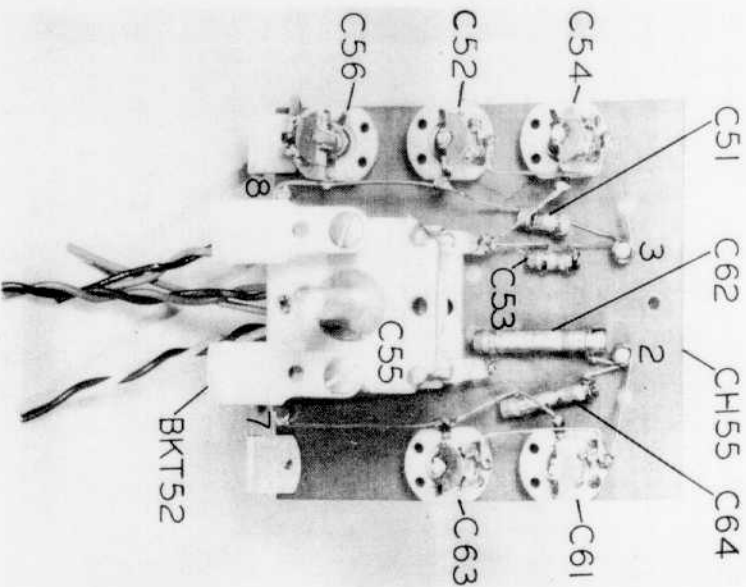

FIGURE 1c
FRONT CONDENSER
TERMINAL BOARD

PART D: PHOTOGRAPHS, CHARTS, AND SCHEMATIC DIAGRAMS

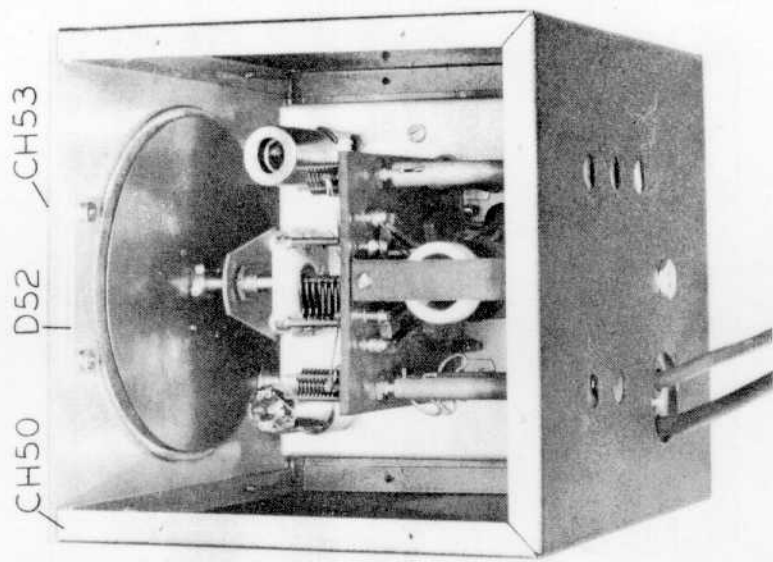

FIGURE 2c
CABINET TOP

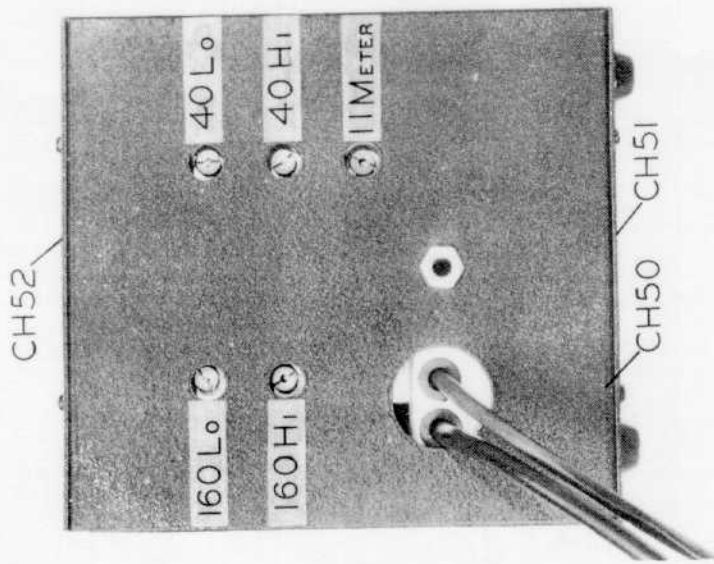

FIGURE 2b
CABINET BACK

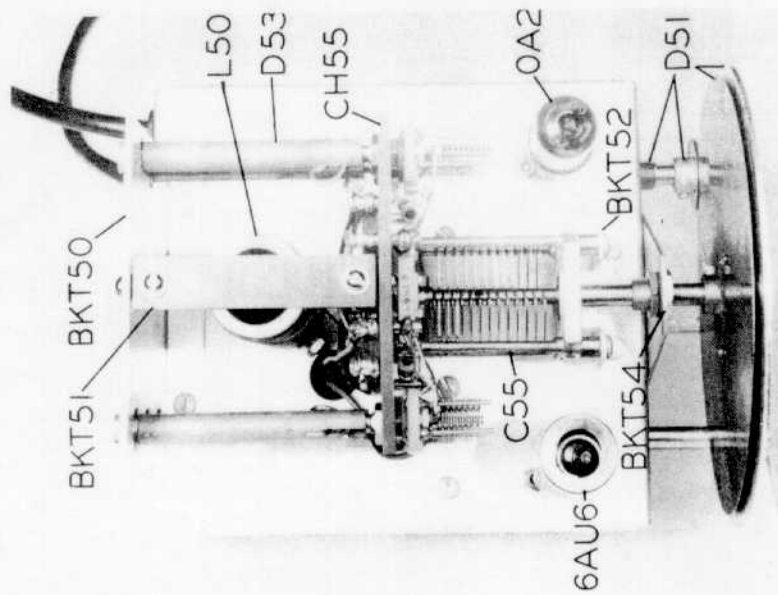
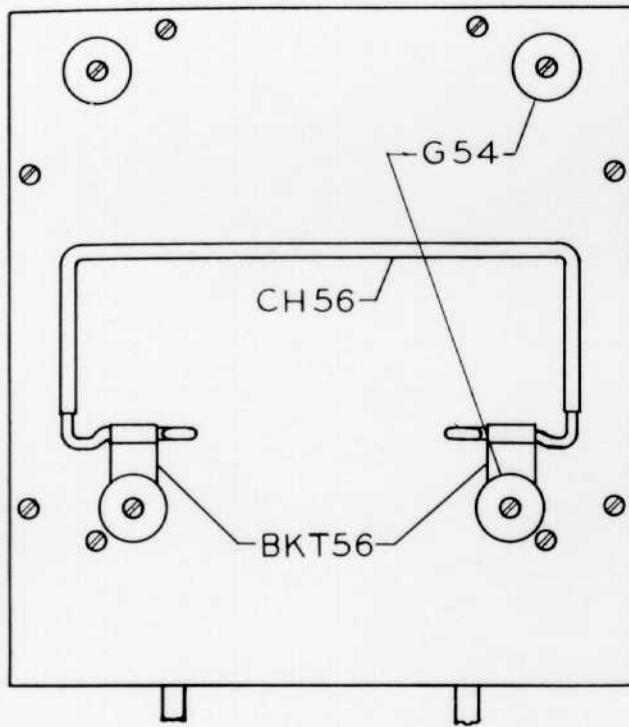

FIGURE 2a
CHASSIS TOP

FIGURE 3a



CABINET BOTTOM AND TILT STAND

FIGURE 3b

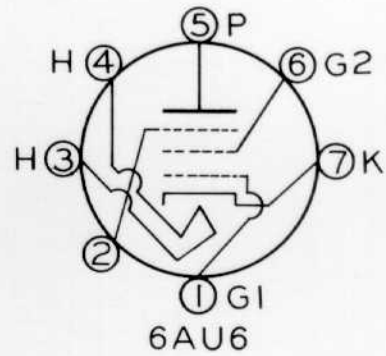

6AU6

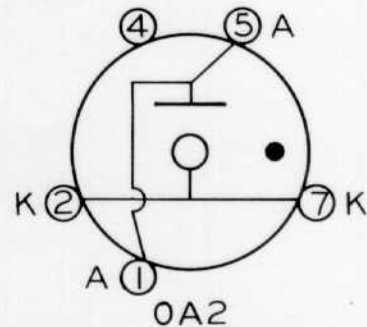

0A2

SOCKET CONNECTIONS
BOTTOM VIEW

	SIGNIF. FIGURE	DECIMAL MULTIP.	PERCENT TOLER.	TEMP. COEFF.	CHARACTERISTIC	VOLTAGE RATING
BLACK	0	1		NPO	A	100
BROWN	1	10		NO30	B	200
RED	2	100		NO80	C	300
ORANGE	3	1000	3*	N150	D	400
YELLOW	4	10000		N220	E	500
GREEN	5		5	N330	F	600
BLUE	6		6	N470	G	700
VIOLET	7		7	N750		800
GRAY	8		8			900
WHITE	9		9#			500
NO COLOR			20			

* #ON CERAMIC CONDENSERS; * IS 2.5%, # IS 10%

FIXED RESISTORS

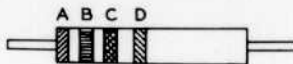

A-FIRST SIGNIF. FIGURE
B-SECOND SIGNIF. FIGURE
C-DECIMAL MULTIPLIER
D-TOLERANCE IN PERCENT
GOLD 5%
SILVER 10%
NO COLOR 20%

FIXED CERAMIC CAPACITORS

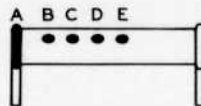

A-TEMPERATURE COEFF.
B-FIRST SIGNIF. FIGURE
C-SECOND SIGNIF. FIGURE
D-DECIMAL MULTIPLIER
E-TOLERANCE

FIXED CAPACITORS

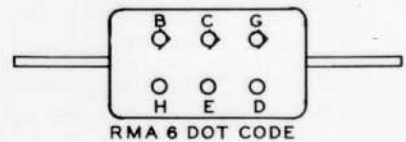

RMA 6 DOT CODE

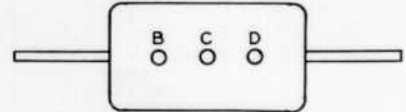

RMA 3 DOT CODE

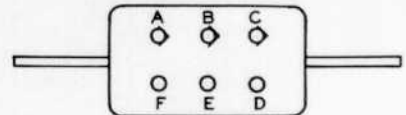

JAN FIXED

A-MICA BLACK PAPER SILVER
B-FIRST SIGNIF. FIGURE
C-SECOND SIGNIF. FIGURE
D-DECIMAL MULTIPLIER
E-TOLERANCE
F-CHARACTERISTIC
G-THIRD SIGNIF. FIGURE
H-VOLTAGE RATING

FIGURE 3c, RESISTOR-CONDENSER COLOR CODES

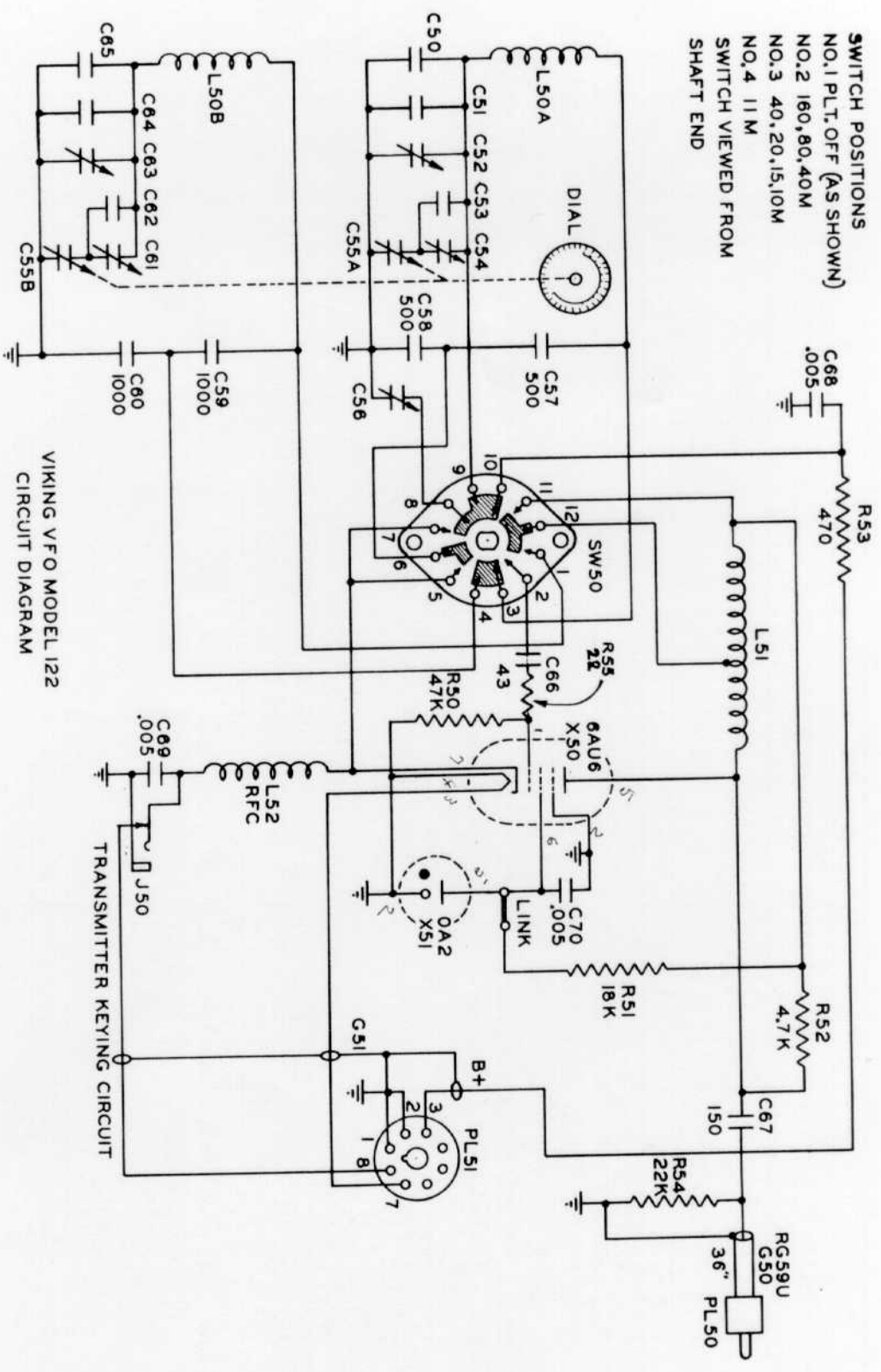

FIGURE 4

VIKING VFO MODEL 122

Parts List

<u>Part No. or Drawing No.</u>	<u>Item No.</u>	<u>Qty.</u>	<u>Description</u>
17.789-1	CH50	1	Cabinet sides and back
17.790-1	CH51	1	Cabinet bottom
17.790-2	CH52	1	Cabinet top
17.791-3	CH53	1	Panel
17.788-1	CH54	1	Chassis
23.966-1	CH55	1	Condenser Mounting Board Assembly
23.979	CH56	1	Tilt stand
16.1053-1	BKT50	1	Rear trimmer coupling bracket
23.962	BKT51	1	Coil support bracket assembly
16.25-1	BKT52	2	Condenser mounting bracket
16.857-4	BKT53	1	Switch mounting bracket
16.857-3	BKT54	1	Dial mounting bracket
16.120-7	BKT55	1	Output coil clamp piece (spacer)
16.1060	BKT56	2	Tilt stand bracket
13.123-7	D50	1	Panel bearing (in 3/8" hardware env.)
23.969-1	D51	1	Dial drive assembly
23.971-1	D52	1	Escutcheon, index assembly
23.970-1	D53	5	Insulated coupling shaft assembly
23.980-3	K52	2	Knob
22.113-1	G53	3	Rubber grommet 9/16 OD
22.632-1	G54	4	Rubber bumpers
71.91-100	W50	4 ft.	Black plastic covered #20 copper wire
71.91-105	W51	7 in.	Green plastic covered #20 copper wire
71.91-102	W52	7 in.	Red plastic covered #20 copper wire
71.91-104	W53	1/2 ft.	Yellow plastic covered #20 copper wire
71.91-101	W54	1/2 ft.	Brown plastic covered #20 copper wire
71.91-108	W55	1/2 ft.	Gray plastic covered #20 copper wire
71.91-106	W56	1/2 ft.	Blue plastic covered #20 copper wire
		1	#6 hardware envelope
		1	#4 hardware envelope
		1	3/8" hardware and terminal envelope
22.794	SW50	1	VFO bandswitch (4 pos.)
23.968	L50	1	Dual oscillator coil assembly
23.967	L51	1	Output coil assembly
102-750	L52	1	Radio frequency choke
22.1246	J50	1	Single contact closed circuit jack
22.695	PL50A	1	PL259 coaxial plug
22.799	PL50B	1	UG176U coaxial adapter
71.32-178	G50	3 ft.	RG59U coaxial cable
71.32-202	G51	3 1/2 ft.	Belden #8735 - 3 cond. shielded cable
22.800	PL51	1	Male connector Amphenol 86-PM8
120-277-1	X50, X51	2	7 pin miniature sockets (shielded)
22.740-5	X52	1	"2005" Jones terminal strip
133-278-7	S50	1	1 3/4" miniature tube shield
22.717	R50	1	47,000 or 51,000 ohm 1/2 watt resistor
22.802	R52	1	4,700 ohm 1/2 watt resistor
22.801	R53	1	470 ohm 1/2 watt resistor
22.716	R54	1	22,000 or 24,000 ohm 1/2 watt resistor
22.713	R55	1	22 ohm 1/2 watt resistor
160-104-24	C52	1	9M11 var. cond. (rotor term. opposite side)
22.803	R51	1	18,000 ohm 2 watt resistor

VIKING VFO MODEL 122

Parts List

<u>Part No. or Drawing No.</u>	<u>Item No.</u>	<u>Qty.</u>	<u>Description</u>
160-107-24	C54	1	15M11 var. cond. (rotor term. opposite side)
160-130-1	C61	1	30M8 variable condenser
160-107-1	C63, C56	2	15M11 variable condenser
169-17	C55	1	Special LA type variable condenser
22.804	C57, C58	2	500 mmfd. +2% silver mica condenser
22.805	C59, C60	2	1000 mmfd. +2% silver mica condenser
22.827	C68, C69, C70	3	.005 mfd. 500 V. W. bypass condenser
22.806	C51	1	47 + 2 1/2% mmfd. N220 ceramic condenser
22.807	C53, C66	2	43 + 2 1/2% mmfd. NPO ceramic condenser
22.808	C67	1	150 + 2 1/2% mmfd. NPO ceramic condenser
22.809	C64	1	91 + 2 1/2% mmfd. N080 ceramic condenser
22.810	C50, C65	2	6.8 + 0.5 mmfd. NPO ceramic condenser
22.823	C62	1	140 + 2 1/2% mmfd. NPO ceramic condenser

JOHNSON VIKING I / VIKING II
AND
VIKING MODEL 122 VFO
KEYER MODIFICATION

A. Theory of Operation

Grid-block keying is used in the crystal oscillator and buffer stages of the Viking I and Viking II, and is also applied to the oscillator of the Model 122 Viking VFO when used as the frequency control. To avoid unnecessary interference with signals on adjacent channels, a wave-shaping filter consisting of R205, R206, and C205 is used on V5, the buffer tube and V6, the oscillator tube. To avoid a chirpy signal when keying the VFO, the keyer tube, V201, allows the VFO to start quickly (a few microseconds) before V5 and V6 start conducting - and then continues operating momentarily after V5 and V6 have stopped conducting.

The VFO keyer adjust control, R202, adjusts the "hold" time for VFO operation after the key is opened. This may be adjusted to cut off the VFO between marks of keyed characters and thus allows rapid CW break-in operation by enabling the operator to be aware of incoming signals while he is keying the transmitter.

When operating in this fashion, a slight sparking at the key may be noticed as a click in the associated receiver. It is not on the carrier and will only be noticed in the receiver used at the transmitter. The clicks can be reduced by installing a 2 1/2 millihenry rf choke (the ordinary receiver type) in each key lead making the connection as close to the key as possible, and connecting a .01 mf capacitor in series with a 500 ohm resistor across the key contacts. This reduces radiation of the spark energy by the key leads.

B. Viking I / Viking II Keyer Modification Assembly Instructions

1. Mount the following components referring to diagram, Fig. 21, making sure that the tube socket and variable resistor are oriented as shown.
 - a. Mount X201, the 9 pin miniature socket, using two 1/4 x 4-40 screws, two #4 lockwashers and two 4-40 hex nuts (use lockwashers between chassis and saddle of socket.)
 - b. Mount R202, 100,000 ohm potentiometer; using the 3/8-32 hex nut and 3/8 lockwasher. Place the lockwasher between the shoulder of the control mounting bushing and the keyer plate. Secure with the 3/8-32 hex nut, orienting the terminals as shown in Figure 21.
2. Make the following ground connections using a 3" length of black wire stripped of its insulation:
 - a. Pins 4 and 5 of X201 to ground lug adjacent pins 4 and 5 of X201. Solder.
 - b. Ground lug adjacent pin 9 of X201 and terminal 1 of R202, the 100,000 ohm potentiometer, do not solder.

Strip insulation from a 1" length of black wire and connect pins 3, 8 and center shield. Solder pin 3 and center shield only.

4. Cut an 11" length of black plastic covered wire, strip 1/4" on each end. Connect this lead to terminal 1 of R202 and solder.
5. Cut a 17 1/2" length of white plastic covered wire, strip 1/4" on each end. Connect one end to terminal 3 of R202. Do not solder.
6. Cut a 13 1/2" length of green plastic wire, strip 1/4" on each end. Connect one end to pin 6 of X201. Do not solder.
7. Cut a 9" length of brown plastic wire, strip 1/4" on both ends. Connect one end to pin 9 of X201 and solder.
8. Cut a 12 1/2" length of red plastic wire, strip 1/4" on both ends. Connect one end to pin 1 of X201 and solder.
9. Cut a 12 1/4" length of orange plastic wire, strip 1/4" on both ends. Connect one end to pin 2 of X201. Do not solder.
10. Cut both leads of R201, 22,000 ohm 1/2 watt resistor, to 5/8" length. Connect between pin 6 of X201 and ground lug opposite pin 9 of X201. Solder both ends.
11. Cut both leads of R204, 18,000 ohm 1/2 watt resistor, to 3/4" length. Connect between pin 8 of X201 and terminal 3 on R202. Solder pin 8 on X201 only.
12. Cut both leads of R205, 22,000 ohm 1/2 watt resistor, to 5/8" length. Connect one end to pin 2 on X201 and other end to terminal 3 of R202. Solder both connections.
13. Cut both leads of R203, 1 megohm 1/2 watt resistor, to 3/8" length. Connect one end to pin 7 of X201 and the other end to the center terminal, 2 on R202. Solder both connections.
14. Inspect entire unit for any unsoldered connections and solder at this time.
15. Dress the six wires as shown in Figure 21 and slip them through a 5" length of .208 inch I.D. spaghetti tubing. Push the tubing along the wires until it extends inside the edge of the keyer chassis.
16. This completes the assembly of the keyer.

C. Installation of Keyer Assembly in Viking I or Viking II.

1. Remove top cover and bottom plate of Viking transmitter.
2. Remove shield S4B, the larger shield adjacent to the final amplifier, by removing the five 6-32 nuts and lockwashers beneath the chassis and two 6-32 nuts and lockwashers which secure it to the small shield. (In Viking I the larger shield is called S4A).
3. Drill two 5/32 inch diameter holes in shield S4B in the locations shown in Figure 22.

4. Mount the keyer chassis to the shield S4B by means of the two aluminum spacers, the two #32 x 1" binder head screws, two lockwashers and nuts. The keyer will mount over the crystal board with the keyer leads toward the rear of the chassis.
5. Referring to Figure 10 in the Operation Instruction Manual, mount a two terminal strip, TS203, under the nut which secures the end of S4A, the shield which mounts the oscillator tuning capacitor. This nut is located to the right of snout SH5 near the chassis side wall. (In Viking I the smaller shield is called S4B.)
6. Remove the grey wire and one lead of shunt SH5 from pin 2 of X5, leaving capacitor C27 connected. Do not solder.
7. Connect shunt SH5 and the grey lead to the ungrounded terminal of the terminal strip, TS203. Do not solder.
8. Cut the leads of R209, 470 ohm 1 watt resistor, to a length of 1/2". Connect the resistor between pin 2 of X5 and the ungrounded terminal of the terminal strip TS203. Solder both connections.
9. In following steps, note that terminals on terminal strips are numbered from the center of the chassis outward.
10. Remove the wire with the black and brown tracer from terminal #5 of X20. Tape the end and tuck it out of the way.
11. Remove the brown wire from the center terminal on X24. Tape the end and tuck it out of the way. (On Viking I there is no X24, so remove the brown lead from pin 8 of X12.)
12. Remove mounting screw and solder lug at the rear end of X20. In place of the lug, mount a two terminal strip, TS201, using the original hardware.
13. Remove the solder lug from C17 and connect C17 to the ground terminal of TS201. Do not solder.
14. Remove one lead of shunt SH3 and two brown wires from terminal 2 of X20.
15. Connect one lead of shunt SH3, just removed, to the ground terminal of TS201. Do not solder.
16. Remove the two brown wires from terminal 2 on SW3. (Terminal 1 in Viking I).
17. Set meter switch to "OFF" position.
18. Use a volt-ohm meter and check continuity of the two brown wires just removed from SW3. One wire should show continuity with one of the two brown wires previously removed from terminal 2 on X20. Connect this wire back on terminal 2 of SW3 and solder. Ground the remaining wire to the solder lug secured by the front end of terminal strip X21 and solder.
19. Connect the brown wire, which shows continuity with the one now on SW3, back on terminal 2 of X20. Tape the remaining brown wire and tuck it out of the way.

20. Mount a two terminal strip, TS202, under the nut and lockwasher which is between the two small rubber grommets near the buffer tuning capacitor, C22.
21. Cut a piece of orange wire 4" long. Strip both ends and connect the ungrounded terminals of TS201 and TS202 which were added. Do not solder.
22. Remove the resistor, R18, ^{470K} from the V6 grid and the ground terminal. Replace R18 with a new resistor, 100,000 ohm 1/2 watt, and connect between pin 1 of X6 and the ungrounded terminal of the terminal strip TS201. Do not solder at TS201. Solder at pin 1 of X6.
23. Cut the leads of R208, 150,000 ohm 1/2 watt resistor, to a length of 9/16". Connect one end to the ground lug on the two terminal strip TS202 and the other end to the ungrounded terminal. Solder the grounded terminal.
24. Cut the leads of R207, 47,000 ohm 1/2 watt resistor, to a length of 3/4". Connect one end to terminal 5 of X20, the other end to the ungrounded terminal of TS202. Solder at the two terminal strip, TS202, only.
25. Cut the leads of R206, 10,000 ohm 1/2 watt resistor, to a length of 3/4". Connect between terminals 5 and 2 on X20 being careful not to short to adjacent terminals. Do not solder.
26. Cut leads on C205, .22 mfd 200 V capacitor, to a length of 1 1/4". Connect between terminal 5 on X20 and the ground lug on the two terminal strip TS201. Solder terminal 5 on X20.
27. Cut leads on capacitor C201, .005 mf ceramic to a length of 1 1/2" and connect between ground terminal and ungrounded terminal of the two terminal strip, TS201. Solder both terminals.
28. Place a large rubber grommet into the hole directly in front of filter choke L3 (refer to Figure 10d in the Viking II Operation Instruction Manual). For the Viking I drill a 1/2" diameter hole located 3 9/16" from the rear of the chassis and 3 1/8" from the left hand edge of the chassis, being careful not to damage the small filter choke, L3, under the chassis. Refer to Figure 10 in the Viking I Operation Instruction Manual. Place a rubber grommet in this hole.
29. Guide the keyer cable through this grommet. Mount shield S4B with keyer assembly attached, back on chassis and secure it by means of the seven lockwashers and nuts previously removed from it.
30. Dress the green lead from the keyer cable toward the cable on the side of the chassis and connect it to the center terminal on X24. Solder this terminal. (On Viking I there is no X24, so connect the green lead to pin 8 of X12.
31. Dress the brown and black wires behind the fuse holder, X16, and connect the black wire to pin ~~3~~ on X11, the brown wire to pin ~~4~~ on X11. Solder both connections.
32. Dress the remaining wires in the cable toward the front, keeping clear of the crystal sockets. Run the white wire along side the bracket for X7 and X17 and connect to terminal 2 on X21. Solder this connection.

CHECK THIS FILE CONNECTION.

WIRE WAS OPPOSITE. F.U.

33. Connect the orange wire to terminal 2 on X20 and solder.
34. Connect the red wire to terminal 4 on X20 and solder.
35. Tape together the 3 wires just installed and secure them to the orange wire installed between TS201 and TS202.
36. Disconnect the center conductor of the small coaxial cable from terminal 2 on the crystal switch, SW8.
37. Remove the tie bolt nearest terminal 2 of the crystal switch, SW8, being careful to save the nut, washer, spacer and bolt.
38. Using the hardware just removed, mount a two-terminal strip, TS205, on the front side of the detent plate of the crystal switch SW8, where the tie bolt was just removed. Orient TS205 with the terminals pointing forward and the ungrounded terminal nearer to where the bottom plate would be. Be careful to replace the spacer between the detent plate and the phenolic wafer. Tighten securely.
39. Connect the center conductor of the small coaxial cable (just disconnected) to the ungrounded terminal of TS205. Do not solder.
40. Cut both leads of C203, .005 mf disc capacitor, to 3/4" length and connect between the ungrounded terminal of TS205 and terminal 2 of the crystal switch, SW8. Solder both connections.
41. Visually inspect all connections and solder any connections which may have been overlooked.
42. Replace V6 (6AU6) with a 6BA6 tube.
43. Install the 12AU7 tube, V201, in socket X201 on the keyer chassis.
44. Replace the bottom plate and top cover on the transmitter.
45. This completes the keying modification on the Viking I or Viking II. The transmitter will provide click-free keying with greatly reduced adjacent channel interference. However, if a VFO is used, it will be necessary to modify the VFO circuitry as described in the following section, D. VFO modification instructions are provided for the Johnson Model 122 VFO only - we cannot underwrite correct keying performance with other VFO units.

D. Viking VFO Model 122 Keying Modification

1. Remove bottom and top cover.
2. Disconnect R50, 47,000 ohm 1/2 watt resistor, and capacitor C70, .005 mfd. and pin 3 of X50 from the ground lug beside terminal 3 of X50.
3. Remove ground lug and replace it with a two terminal strip, TS204.
4. Connect R50, 47,000 ohm 1/2 watt resistor, to the ungrounded lug on terminal strip, TS204. Do not solder.
5. Cut the leads of C202, .005 mf capacitor, to a length of 1/2". Connect across the terminals of TS204. Do not solder.

6. Connect pin 3 of X50 and the end of C70 to the ground terminal on TS204. Solder.
7. Remove the white wire with black tracer from J50 and extend it by adding a piece of brown plastic wire 6" long. Cover the joint with a 2" length of .133 I.D. plastic tubing. Connect this wire to the ungrounded lug on the terminal strip, TS204. Solder.
8. Remove L52 from J50 and connect it to the ground lug directly in front of SW50, the handswitch. Solder this connection.
9. Visually inspect all connections and solder any connections which have been overlooked.
10. Replace bottom and top cover.
11. This completes the modification of the Viking VFO.

E. Adjustment

1. Couple the VFO output to a receiver by placing the open end of the coaxial cable connector (on the Viking VFO output cable) near the antenna terminals of the receiver.
2. Insert key in the key jack in the Viking I or Viking II. The key jack in the VFO will not be used.
3. Close key and tune receiver to VFO signal.
4. Open key.
5. Turn keyer adjust control; R202, clockwise until VFO signal starts.
6. Turn keyer adjust control counter-clockwise just slightly beyond the point at which the VFO signal stops. Adjustment in the extreme counter-clockwise position may cut off the VFO too soon and result in "squaring" or "sharpening" of the keying envelope at the break with attendant clicks.
7. Connect the VFO output coaxial cable to the input connector on the Viking II.

F. D.C. VOLTAGES TO GROUND - Measured with a 20,000 - ohms-per-volt Voltmeter

Keyer V201
Type 12AU7

<u>Pin</u>		<u>Key Open</u>	<u>Key Closed</u>
1	Plate	+ 350	+ 320
2	Grid	- 68	0
3 and 8	Cathodes	- 41	+ 16
4	Heater	0	0
5	Heater	0	0
6	Plate	- 20	- 1
7	Grid	- 41	- 23.5
9	Heater	6.3 VAC	6.3 VAC

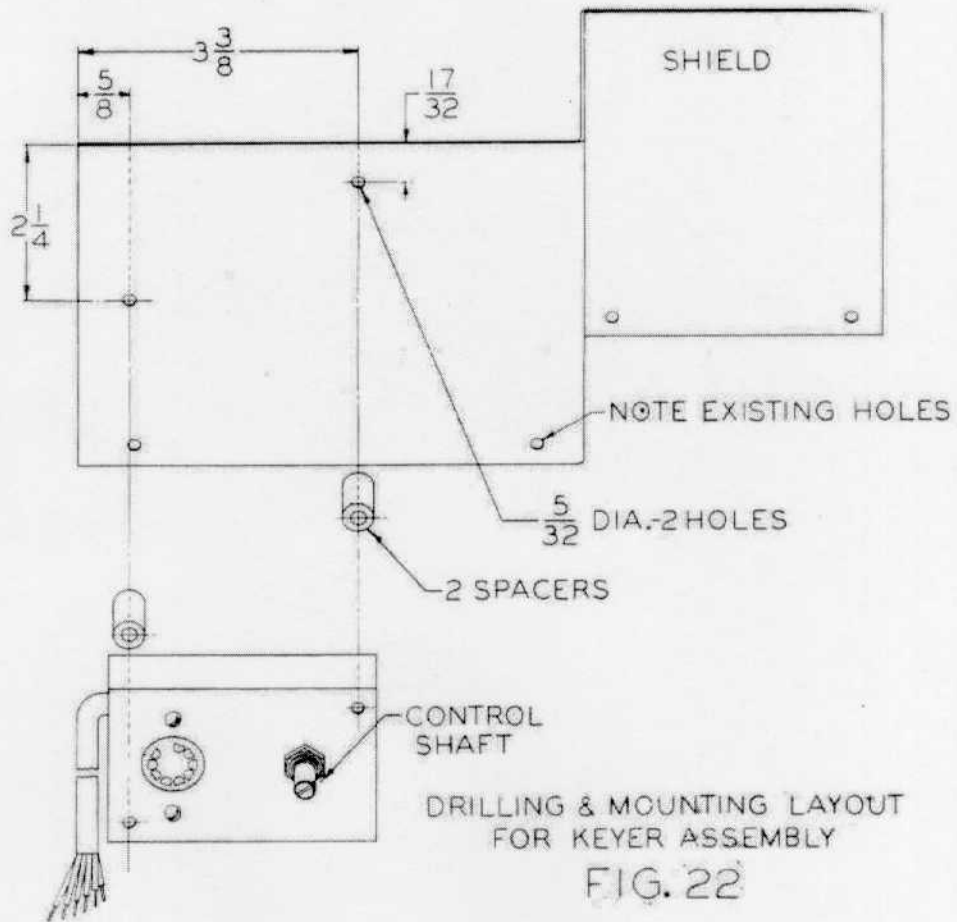
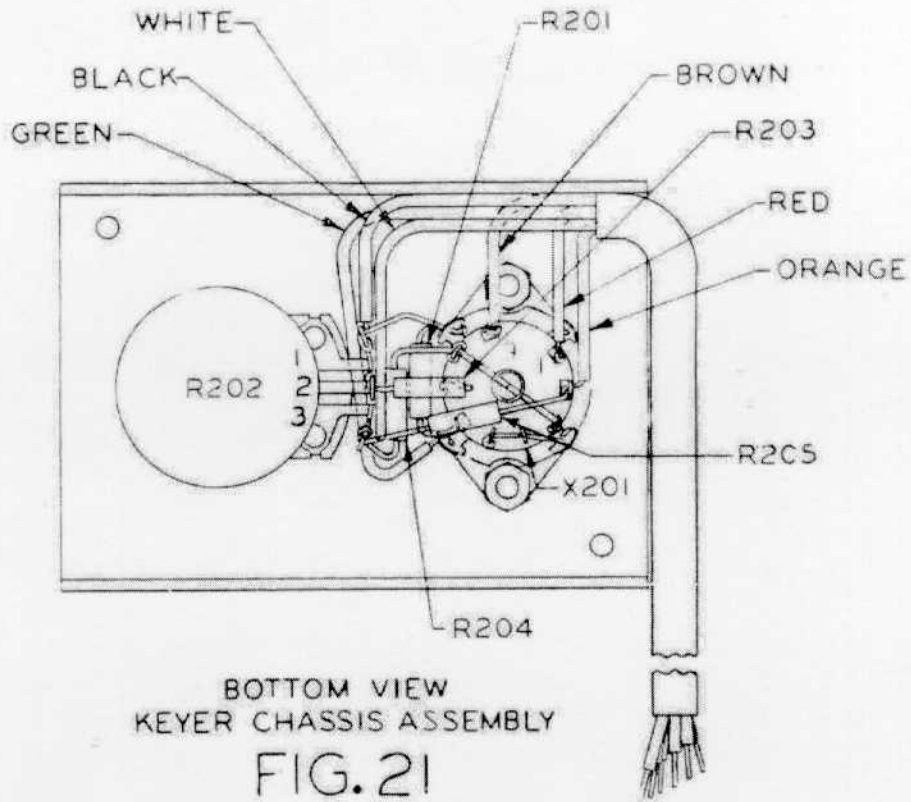

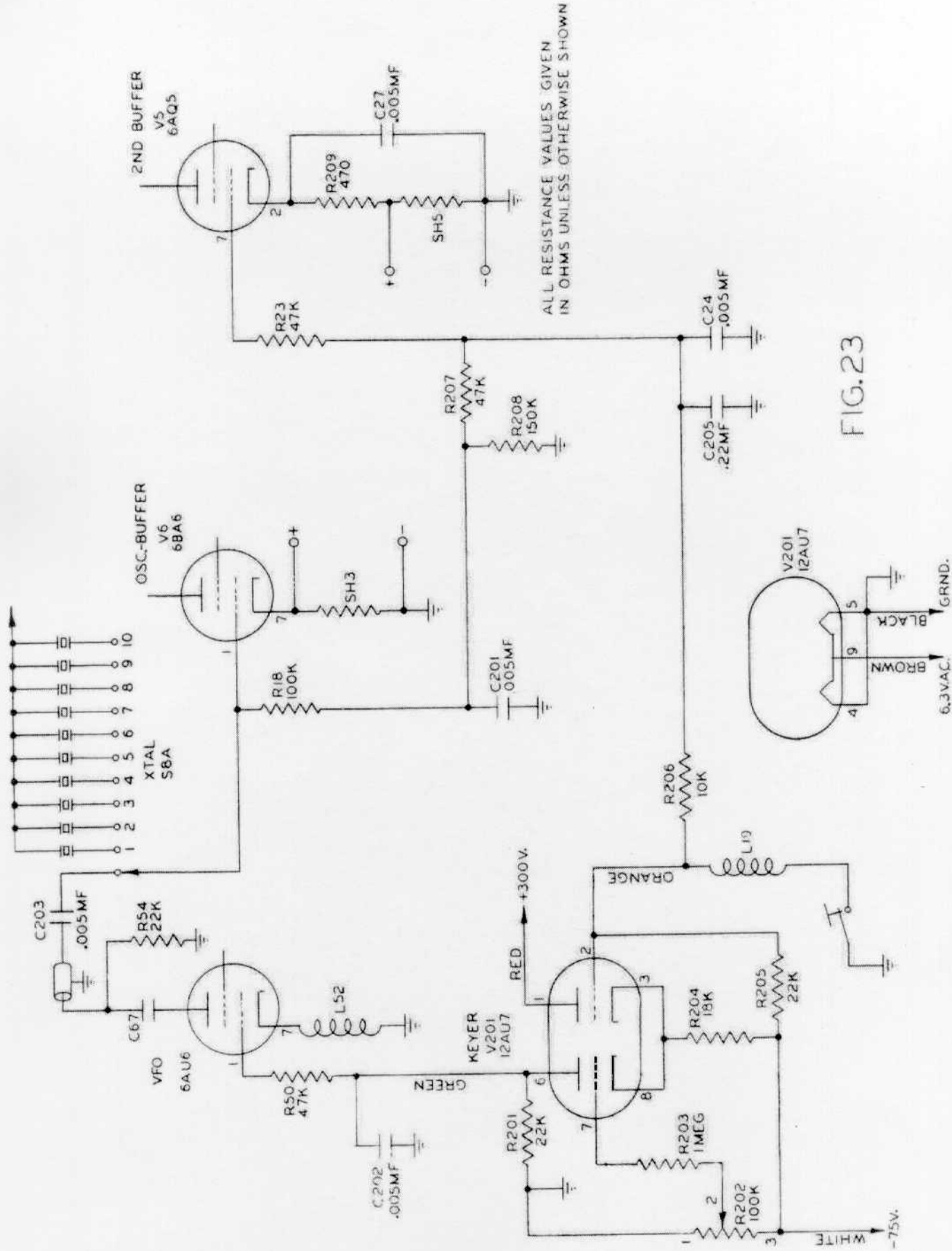

FIG. 23