



**Johnson**  
electronic equipment

**OPERATING MANUAL  
VIKING II-CDC  
TRANSMITTER**



**E. F. Johnson Company**

W A S E C A , M I N N E S O T A

# STANDARD WARRANTY

Adopted and Recommended by the  
Electronic Industries Association

The E. F. Johnson Company warrants each new radio product manufactured by it to be free from defective material and workmanship and agrees to remedy any such defect or to furnish a new part, except for electron tubes, in exchange for any part of any unit of its manufacture which under normal installation, use and service disclosed such defect, provided the unit is delivered by the owner to us or to our authorized radio dealer or wholesaler from whom purchased, intact, for our examination, with all transportation charges prepaid to our factory, within ninety days from the date of sale to original purchaser and provided that such examination discloses, in our judgement, that it is thus defective.

This warranty does not extend to any of our radio products which have been subjected to misuse, neglect, accident, incorrect wiring not our own, improper installation, unauthorized modifications, or to use in violation of instructions furnished by us, nor extend to units which have been repaired or altered outside of our factory, nor to cases where the serial number thereof has been removed, defaced or changed, nor to accessories used therewith not of our own manufacture, nor to electron tubes.

The Radio Parts Distributor will assume the responsibility for replacement or exchange of any component part of a unit approved for remedy or exchange hereunder, through the factory Customer Service Department, without charge to the owner.

Defective electron tubes and executed service report should be returned prepaid directly to the tube manufacturer for adjustment at the following addresses:

(a) RCA tubes to: Adjustment Service, RCA at the nearest of the following addresses:  
34 Exchange Place                      3601 South Adams St.                      6355 East Washington Blvd.  
Jersey City 2, N. J.                      Marion, Indiana                      Los Angeles 22, California

(b) General Electric tubes to:                      (c) Amperex tubes to:                      (d) Eimac tubes to:  
Adjustment Service                      Amperex Electronic Corp.                      Eitel-McCullough, Inc.  
Owensboro Tube Works                      230 Duffey Avenue                      San Bruno,  
General Electric Co.                      Hickville, Long Island                      California  
Owensboro, Kentucky                      New York

(e) Sylvania tubes to: Any Authorized Sylvania Distributor.

This warranty is in lieu of all other warranties expressed or implied and no representative or person is authorized to assume for us any other liability in connection with the sale of our radio products.

**NOTE: Tubes marked "E. F. Johnson Co.," regardless of manufacturer, should be returned to E. F. Johnson Co., Waseca, Minnesota.**

E. F. JOHNSON COMPANY VIKING II-CDC TRANSMITTER

SPECIAL WARNING

In the Viking II-CDC Transmitter, reserve grid driving capability has been provided so as to insure adequate excitation on all frequencies and to allow for variations in individual wiring.

The RCA type 6146 beam power tubes used in the final amplifier have a maximum D.C. grid current rating of 4 ma. per tube.

When 6146 tubes have been overdriven it is evidenced by a negative D.C. grid current reading.

The total grid current should not exceed 8 ma. at any time as exceeding this value may possibly damage the tube and will void the guarantee of the tube manufacturer.

DO NOT EXCEED 8 MA. GRID DRIVING CURRENT AT ANY TIME

SPECIAL WARNING

In the Viking II-2DC Transmitter, reserve grid driving capability

has been provided so as to insure adequate excitation on all frequencies and

to allow for variations in individual wiring.

The 6CA type 614C beam power tubes used in the final amplifier

have a maximum D.C. grid current rating of 4 ma. per tube.

When these tubes have been overdriven it is evidenced by a negative

D.C. grid current reading.

The total grid current should not exceed 8 ma. at any time an ex-

ceeding this value may possibly damage the tube and will void the guarantee

of the tube manufacturer.

DO NOT EXCEED 8 MA. GRID DRIVING CURRENT AT ANY TIME

## SPECIAL SET-UP INSTRUCTIONS FOR FACTORY WIRED TRANSMITTERS

1. Remove all packing materials and accessories from inside the transmitter including the transformer shipping braces. Pull the nails from the braces, slide blocks toward front panel. The long brace may then be turned slightly and lifted out.
2. Remove bottom plate and take out the three wood blocks. Do not replace the bottom plate at this time.
3. Install 6146 tubes in sockets X7 and X17 and install plate caps. (Reference, Figure 1 in Instruction Manual.) Check to see that all tubes are seated in their sockets with shields and plate cap connectors in place. Shields are not used for V28, 6AQ5 screen clamper, and V11, 6AL5 bias rectifier.
4. Attach knobs to shafts per instructions on pages 7 and 8 of Operating Manual. Place "Fil" and "Plate" toggle switches in Off (down) position.
5. Initial checks should now be made using, if possible, a dummy load. A standard 100 watt lamp will serve very well for this purpose. Connect the center contact of the lamp to the center contact of J3 (refer to Figure 2 of Manual). Connect the shell of the lamp base to the ground terminal adjacent to J3.
6. With the line cord connected to a 117 volt 60 cycle power source and before installing a crystal or VFO, turn on the low voltage supply (left hand toggle switch on front panel).
7. Oscillator current should rise to between 17 and 23 ma. Set the "drive" control at mid-position.
8. Screen voltages for the 6146 amplifiers V7 and V17 and for the 807 modulators V3 and V4 have already been adjusted by means of the tap on R13 and the potentiometer R30 (adjacent to L10). **DO NOT CHANGE THESE ADJUSTMENTS UNLESS THE TEST UNDER STEP 9, FOLLOWING, INDICATES IT IS NECESSARY.**
9. Switch the Phone/CW switch to the CW position. Turn on high voltage (right hand toggle switch) and observe "Plt" current. The plate current should be less than 25 ma. It may prove to be as low as 10 ma., however, and this is quite normal. Should the "Plt" current exceed 25 ma., turn high voltage switch OFF at once.
10. If the Plate current in step 9 exceeds 25ma., readjust the screen clamper tube per the instructions on page 11.
11. With plate current normal as in step 9, you are now ready to proceed with the tuning instructions beginning on page 9.
12. The transmitter is normally tuned in the CW position. In a properly adjusted transmitter delivering full output the 6 ma. excitation to the 6146s will rise to 8 ma. or more when the high voltage is switched off. Therefore, when making tuning adjustments on CW always reduce drive when the high voltage is cut off.
13. After thoroughly testing the transmitter, replace the bottom plate and secure all screws.

THE HISTORY OF THE UNITED STATES

The first part of the book is devoted to the early history of the United States, from the discovery of the continent by Christopher Columbus in 1492 to the establishment of the first permanent settlements.

The second part of the book deals with the colonial period, from the early 17th century to the outbreak of the American Revolution in 1776.

The third part of the book covers the Revolutionary War and the early years of the new nation, from 1776 to the end of the 18th century.

The fourth part of the book discusses the early 19th century, from the War of 1812 to the beginning of the Civil War in 1861.

The fifth part of the book deals with the Civil War and Reconstruction, from 1861 to the end of the 19th century.

The sixth part of the book covers the late 19th and early 20th centuries, from the end of Reconstruction to the beginning of World War I.

The seventh part of the book discusses the World War I era, from 1914 to the end of the war in 1918.

The eighth part of the book deals with the interwar period, from the end of World War I to the beginning of World War II.

The ninth part of the book covers World War II, from 1939 to 1945.

The tenth part of the book discusses the post-World War II era, from 1945 to the present.

The eleventh part of the book deals with the Cold War, from the end of World War II to the end of the 1980s.

The twelfth part of the book covers the end of the Cold War and the beginning of the 21st century.

The final part of the book discusses the current state of the United States and the world.

## Viking II-CDC Transmitter Installation and Operation

The successful operation of any radio equipment is largely dependent on the operator's understanding of the equipment. This operating instruction manual is set up in several parts, each with the purpose of making the operator more familiar with the Viking II-CDC. The main parts are:

- |   |                     |
|---|---------------------|
| Special Setting Up Instructions<br>for Factory Wired Transmitters | At front<br>of book |
| A. Theory of Operation  |                     |
| B. Initial Installation   |                     |
| C. Viking II-CDC Tuning Details                                   |                     |
| D. Pi-Network Tuning and Harmonic Suppression                     |                     |
| E. Trouble Shooting   |                     |
| F. Photographs, Charts and Schematic Diagrams                     |                     |
| G. Parts List   |                     |

### W A R N I N G

The voltages encountered in this piece of equipment are high enough to cause fatal injury! Practice safety rules until they are second nature. Always turn off the high voltage before making any adjustment inside transmitter. Never depend on a bleeder resistor to discharge filter condensers. After the power is turned off, short circuit the high voltage circuit. Never operate the transmitter with other than the recommended fuse in the primary circuit. The fuse will protect your equipment; in the case of accidental contact with the high voltage, it may save your life. If children have access to the transmitter, always disable the primary circuit by removing the fuse, or the high voltage circuits by removing the rectifiers.

# STANDARD WARRANTY

## Adopted and Recommended by the Electronic Industries Association

The E. F. Johnson Company warrants each new radio product manufactured by it to be free from defective material and workmanship and agrees to remedy any such defect or to furnish a new part, except for electron tubes, in exchange for any part of any unit of its manufacture which under normal installation, use and service disclosed such defect, provided the unit is delivered by the owner to us or to our authorized radio dealer or wholesaler from whom purchased, intact, for our examination, with all transportation charges prepaid to our factory, within ninety days from the date of sale to original purchaser and provided that such examination discloses, in our judgement, that it is thus defective.

This warranty does not extend to any of our radio products which have been subjected to misuse, neglect, accident, incorrect wiring not our own, improper installation, unauthorized modifications, or to use in violation of instructions furnished by us, nor extend to units which have been repaired or altered outside of our factory, nor to cases where the serial number thereof has been removed, defaced or changed, nor to accessories used therewith not of our own manufacture, nor to electron tubes.

The Radio Parts Distributor will assume the responsibility for replacement or exchange of any component part of a unit approved for remedy or exchange hereunder, through the factory Customer Service Department, without charge to the owner.

Defective electron tubes and executed service reports, carefully packed, should be returned prepaid directly to the tube manufacturer for adjustment at the following addresses. Ship power tubes via Railway Express.

NOTE: Tubes marked "E. F. Johnson Co.," regardless of manufacturer, should be returned to E. F. Johnson Co., Waseca, Minnesota.

(a) RCA tubes to: Adjustment Service, RCA at the nearest of the following addresses:

|   |   |  |
|---|---|--|
| 34 Exchange Place<br>Jersey City 2, N. J. | 3601 South Adams St.<br>Marton, Indiana | 6355 East Washington Blvd.<br>Los Angeles 22, California |
|---|---|--|

(b) General Electric tubes to:

Adjustment Service  
Owensboro Tube Works  
General Electric Co.  
Owensboro, Kentucky

(c) Amperex tubes to:

Amperex Electronic Corp.  
230 Duffey Avenue  
Hickville, Long Island  
New York

(d) Eimac tubes to:

Eitel-McCullough, Inc.  
San Bruno,  
California

(e) Sylvania tubes to:

Sylvania Electric Products  
Dept. EFJ  
2001 North Cornell  
Melrose Park, Illinois

(f) Penta tubes to:

Penta Laboratories, Inc.  
312 North Nopal Street  
Santa Barbara, California

This warranty is in lieu of all other warranties expressed or implied and no representative or person is authorized to assume for us any other liability in connection with the sale of our radio products.





3. The BUFFER: Frequency multiplication takes place in the 6AQ5 buffer stage on the three highest band positions. Straight through operation is used on all lower frequency bands. The buffer stage power output is controlled by the "drive" screen grid potentiometer control. Buffer tuning is best indicated by the 6146 final "grid" current, while the oscillator tank tuning is best indicated by maximum buffer cathode current read in the "buffer" meter switch position. The "grid" current must be held below 8 ma. at all times. 6 ma. is adequate to drive the 6146s to full output. Buffer no signal current is limited by a fixed bias of approximately 25 volts applied to the 6AQ5 grid.
4. The R.F. POWER AMPLIFIER: The grid circuit of the final 6146 has a fixed bias of 75 volts with an additional 20 to 30 volts of self bias added by the drive signal. Under no-signal conditions the 6146s are almost completely cut off. The tank of the 6146s is part of a pi network matching-coupling circuit. The main tuning inductor, L9, and geared condenser, C29, tune the range of 3.5-30 mc. The auxiliary switch adds auxiliary coils to cover the range between 1.7 and 3.5 mc. Frequency coverage is shown on curve 1 of the sheet following page 10. The screen and plate current of the 6146s is read when the meter switch is in the "plate" position. Note that the final grid current is not included in this "plate" reading. The screen grid voltage for the 6146s is obtained from the high voltage supply through a 20,000 ohm series dropping resistor.
5. The PI NETWORK ANTENNA COUPLING: The complete pi network consists of the main tuning inductor, L9, as the series element; the main tuning condenser, C29, as the input shunt capacitance made up of a variable condenser, C30, labeled "fine coupling" and a group of fixed mica condensers, C33 through C38, switched in parallel with C30 by a switch labeled "coupling". This combination provides a continuous output capacity range of 20 to 2050 mmfd. The pi tuning-coupling network is designed to match the 6146s into antenna resistances of nominally 50 to 600 ohms and tune out several hundred ohms of antenna reactance over the frequency range of the Viking II-CDC. The range of antenna impedance matching extends roughly from 25 to 2000 ohms at frequencies higher than 7.0 mc. In general high impedance loads will require small output coupling capacities (advanced settings). Reactance cancellation takes place automatically when the "final" control is tuned to the proper plate current dip with the meter switch in the "plt" position. The net tank plate reactance is dependent on the load characteristics and the output coupling capacity but the plate current dip indicates that the 6146 plates are loading into a resonating tank. The plate current dip becomes less and less pronounced as the final 6146s are properly loaded. Advancing the coupling controls beyond a point where a dip of at least 20 ma is observed will usually cause over-coupling, resulting in inefficiency and poor harmonic suppression.
6. The MODULATOR: The modulator section consists of a pair of 807's operating in class AB2 push-pull, driven by a transformer coupled 6AU6 driver, and a 6AU6 resistance-capacitance coupled speech amplifier. The "audio" gain is a potentiometer control of audio input to the driver stage. When the "cw-phone" switch is in the "cw" position the secondary of the modulation transformer is shorted and the screens of the modulation (807) tubes are opened. The "phone" position removes the short and applies screen voltage to the 807's from the high voltage bleeder-driver tap. Sections of the high voltage primary "plate" switch and the "cw-phone" switch are inter-connected in the keying circuit so that the keying circuit is opened whenever the "plate" is off and the "cw-phone" switch is in the "phone" position. This eliminates oscillator interference while listening to a station operating on the same frequency as the Viking II CDC. Frequency response provides excellent quality with ordinary crystal communication microphones

A fast acting audio compressor is used to avoid over modulation. The compressor utilizes a 6J6 dual triode tube which rectifies the audio signal applied to the 807 modulator grids and feeds the rectified voltage back to the audio input stage to control the screen potential and thus the gain.

A high level diode negative peak clipper is used in the modulated high voltage lead to prevent excursions below zero in case of small audio peaks or transients which may get through the low level limiter.

7. The POWER SUPPLIES: The Viking II CDC has three power supplies:

- a. The 6AL5 BIAS SUPPLY furnishes approximately 75 volts bias to the 6146 grid circuit, 35 volts bias to the 807 modulator grids and 25 volts bias to the 6AQ5 buffer-frequency multiplier.
- b. The 5V4G LOW VOLTAGE SUPPLY furnishes power to all filaments and 290 to 310 volts (loaded) to the RF exciter and 6AU6 audio amplifier stages.
- c. The HIGH VOLTAGE SUPPLY furnishes 620 to 660 volts (loaded) to the 6146 final amplifier and 807 modulators. The parallel 5R4GY tubes and 10 henry choke 1 input filter provide good regulation in the operating range of the Viking II CDC. The B- side of the H.V. supply is above ground potential by the 6146 meter shunt voltage (100 millivolts full scale).
- d. 6AQ5 SCREEN VOLTAGE REGULATOR: This tube prevents excessive rise of 6146 screen grid voltage with key up on CW or in the event of the excitation failure while operating on phone. The 6AQ5 is used as a triode with its screen grid and plate connected together to the source of 6146 positive screen voltage. The cathode of the 6AQ5 is connected to the center tap of the high voltage transformer (B-). A 470,000 to 500,000 ohm resistor and 1 megohm potentiometer are connected in series between the slider on the voltage divider R13 and the most negative point of the bias supply at the junction of choke L6 and resistor R24. The grid of the 6AQ5 regulator is connected to the movable arm of the 1 meg. potentiometer. Thus by adjusting the potentiometer any desired grid voltage can be applied to the regulator.

When operating on CW with key down, the regulator tube has cut-off bias applied and draws no current. When the key is opened grid current ceases to flow thru resistor R24 and the voltage at the junction of L6 and R24 becomes less negative. This results in the grid bias of the 6AQ5 regulator shifting in a positive direction. This positive shift causes the 6AQ5 to draw current, applying a load at the source of 6146 screen grid voltage, holding the voltage down even though the 6146 screen grid current has dropped essentially to zero. Should the excitation to the 6146s fail, while operating on phone, the same change in grid voltage occurs and 6146 screen voltage is again restrained. Modulation of the 6146s doubles their screen voltage on peaks but the 6AQ5 bias is sufficiently high so that it remains cut-off.

8. METERING: The cathode currents of the oscillator, buffer, and modulator may be read on the meter when the meter switch is placed on the indicated position.. The 6146 power amplifier combined screen grid and plate currents are read in the "plt" position, and 6146 grid current is read in the "grid" position. All shunts are cut for 100 mv drop for a full scale meter indication. The "osc" or "grid" current are read on the lower 0-25 ma scale, the "bfr" current on the upper scale (assuming 50 ma full scale), and the "plt" and "mod" current on the 0-500 ma upper scale.

9. KEYING of the VIKING II CDC is done in the 6AU6 oscillator cathode circuit. The keying circuit is broken by the H.V. switch (off position) on phone operation as previously described under the "Modulator" section, so it is therefore imperative that the RF exciter tuneup always be accomplished with the mode "cw" position of the cw-phone switch. As may be expected with any conventional oscillator keying, the quality of the keyed characters may depend slightly on the oscillator tank tuning when "straight through" operation is used. The oscillator tuning control can be adjusted for clean stable keying.
10. VFO EXCITATION: The "O" position of the crystal selector switch connects the VFO receptacle at the rear of the chassis directly to the 6AU6 oscillator grid through approximately one foot of RG59U cable. An isolating condenser of 50 to 150 mmfd is necessary between the VFO and Viking II input unless the VFO has a capacity coupled output (the Johnson VFO may be directly coupled). 6 volts of 7 mc RF at the grid of the Viking II CDC 6AU6 oscillator stage will drive the final to full excitation at 30 mc. The lower frequency bands require less VFO output. The VFO frequency range should be nominally the same as the crystal frequencies which would normally be used. CAUTION: There may be a possibility of overdriving the 6AU6 with a VFO resulting in grid blocking. Grid blocking actually reduces the effectiveness of the stage to the point where it attenuates the input signal greatly rather than passing or amplifying the input signal or generating the required harmonics.

When the Viking II CDC is fed with a VFO, it is well to remember that the specified voltage is that required at the Viking II CDC 6AU6 grid and that the VFO transmission line must be loaded in a manner to provide the required voltage at the grid of the 6AU6. An example of this problem is a four foot length of RG59U. It will appear as approximately 85 mmfd of shunting capacity at the VFO output and should be treated as such at frequencies below 10 mc unless excessive VFO output is available and the attenuation of the transmission line is desired.

The VFO must be sufficiently well shielded so that feedback does not exist between the transmitter and the VFO. Monitoring a VFO driven transmitter should be done more carefully than with crystal operation. Keep the VFO and transmitter decoupled from the monitoring receiver to avoid overloading the receiver. Receiver blocking or local oscillator shift due to overloading often causes an unreliable indication of transmitter keying or frequency.

11. The Viking II CDC as an EXCITER for a LARGER TRANSMITTER:

- a. When the Viking II CDC is used as an RF exciter only, tuning and loading procedure will be essentially the same as used with normal transmitter operation. The output of the Viking can be link coupled to the grid stage of the power amplifier. Enough power should be required at the power amplifier grid circuit to load the Viking to at least 30 watts. Shunt dissipating resistors can be added if the grid requirement is too small to load the Viking II CDC sufficiently.
- b. Conversion of the Viking II CDC Modulator to serve as an audio driver is shown on the following sheet. Figure A suggests how a switch or transfer terminal board may be used to connect the modulator to drive the grid of a larger modulator directly and allow normal Viking II CDC operation upon switching or moving the transfer jumpers to the alternate position shown. Figure B shows the connections for feeding the larger modulator grids through a 500 ohm line and audio driver transformer. A hole may be punched in the rear of the Viking

VIKING II-CDC MODULATION TRANSFORMER CONNECTED TO DRIVE A  
LARGER MODULATOR WITH SWITCHING OR TRANSFER FOR NORMAL OPERATION

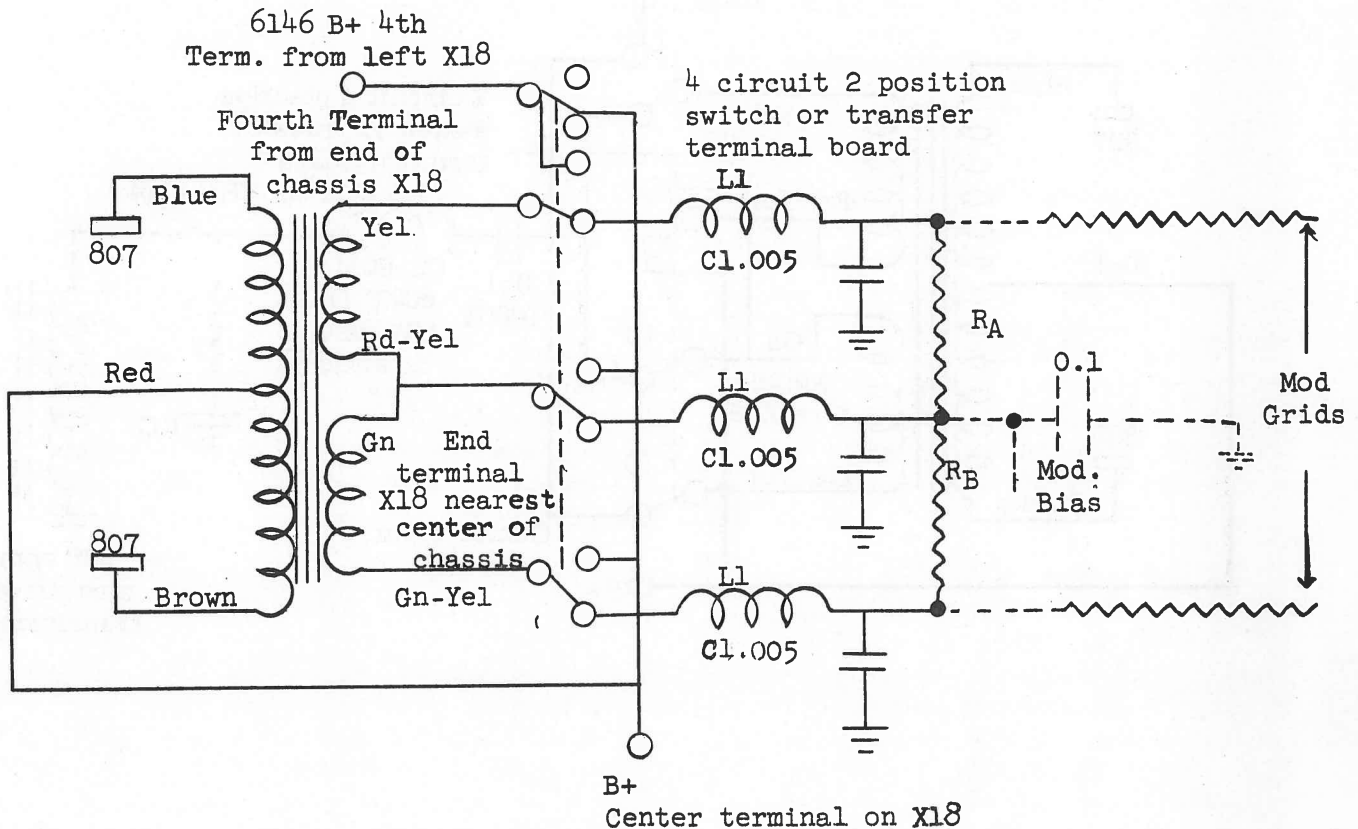

FIGURE A

DIRECT GRID CONNECTION

1. The yellow and gn-yel modulation transformer leads in Figure A and the yellow and red-yel leads of Figure B must be disconnected from present terminations.
2. A 4 circuit 2 position switch may be mounted on the side of the chassis above X4 or a transfer terminal block may be mounted on the outside rear of the chassis. No attempt will be made to provide mounting details as available switches or terminal boards will differ markedly. Steatite switches or terminal boards should be insulated for 1200V between terminals.
3. RA, RB, or RC may be chosen to load Viking II CDC Modulator if quality is impaired by light loading.
4. Permanent connections for exciter operation can be made as indicated by the closed circuits in the switch positions shown above, eliminating the switch or transfer board.

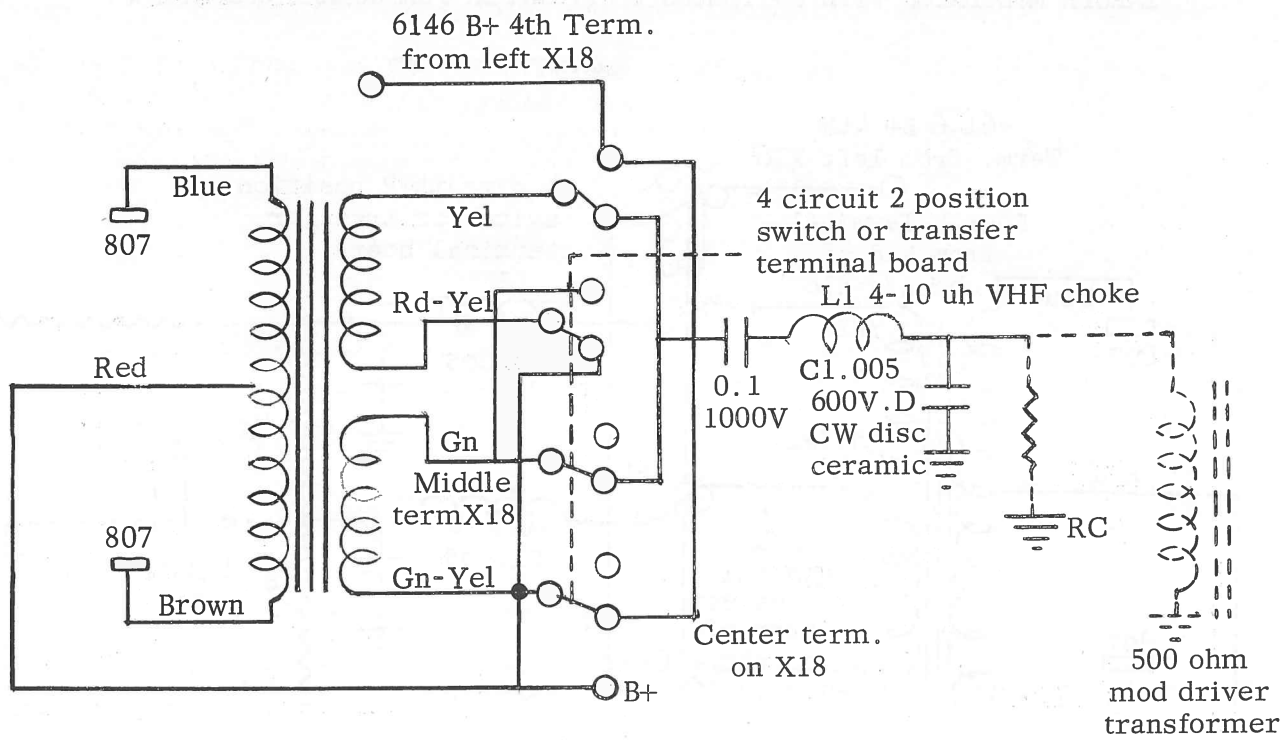

FIGURE B

CONNECTION THROUGH 500 OHM PRIMARY  
OF MODULATOR DRIVER TRANSFORMER

11. b. cabinet to bring out the audio leads conveniently, either directly or through an appropriate connector. Lead filter components, L1 and C1 should be placed inside the transmitter as close as possible to the point where the leads leave the cabinet. These filters are for harmonic and TVI suppression.
- c. Connection of the Viking II CDC as an audio driver in a permanent installation is indicated in Figure A and B. The switches are shown in the driver exciter position; permanent connections can be made ignoring the alternate normal Viking II CDC operating position. The secondary winding of Figure B may be isolated from B+ and grounded which will eliminate the need of the 0.1 mfd D.C. isolating condenser.
12. a. ANTENNA RELAY OPERATION

The twin ceramic terminals on the rear of the chassis provide 115V AC for operation of an antenna relay. The terminals are energized only when switch SW2 (high voltage switch) is in the "on" position. The antenna relay coil or other load connected at this point must be insulated from ground. Fuse F1 protects the circuit from accidental overload.

#### B. INITIAL SET-UP INSTRUCTIONS

1. NOTICE! The regulations of the Federal Communications Commission require a suitable license for operation of this equipment. Refer to publications of the Federal Communications Commission for the latest rules governing station and operator licensing.
2. Be sure to return the enclosed warranty registration card. This will register your transmitter at the factory. If it becomes necessary to write to the factory regarding your transmitter, refer to it by serial number.
3. Remove loose packing material and the packages of parts inside of the cabinet. Inspect the transmitter for any indication of damage. Report any damage to the transportation company immediately.
4. The wired Viking II CDC will arrive with shipping supports consisting of wood blocks and a brace for the transformers.
  - a. The transformer blocks and cross supports piece should be removed.
5. Attach knobs to the shafts. The setscrew may be anchored securely in place (after the knob has been properly positioned) by first tightening down, loosening slightly and retightening. The knob-dials should be put on and positioned as follows:
  - a. CRYSTAL - a 10-0 dial. The 0 located on the maximum counter-clockwise position.
  - b. OSCILLATOR - 100-0 dial. The 0 located on the maximum capacity (low frequency) position.
  - c. FREQ. - a single marker dial. The marker located on the 1.7 -2.3 position with switch in maximum counter-clockwise position.
  - d. BUFFER - a 100-0 dial. The 0 located on the maximum capacity (low frequency) position. The buffer condenser can be seen through the perforated bottom.

5.
  - e. DRIVE - a 10-0 dial. The 0 located on the maximum counter-clockwise potentiometer position.
  - f. CW-PHONE - a single marker dial. The marker located on CW with the switch in the counter-clockwise position.
  - g. FINAL - the large spinner knob. No special positioning is required.
  - h. AUXILIARY - a single marker dial. The marker located on 1.7 - 2.3 position with the switch in the clockwise position.
  - i. COUPLING - the 7-1 dial. The 1 located on the maximum counter-clockwise switch position. (Maximum capacity position).
  - j. FINE COUPLING - a 100-0 dial. The 0 located on the maximum capacity position of the variable condenser.
  - k. AUDIO - a 10-0 dial. The 0 located on the maximum counter-clockwise potentiometer position.
  - l. METER - the MOD PLT GIRD BFR OSC OFF dial. The OFF position located on the maximum counter-clockwise switch position.
6. Insert tubes as follows (the socket locations can be determined from the designations by referring to Figure 1 at the rear of this book):
  - a. The 6AQ5 buffer in X5 with a 2 1/4" shield.
  - b. A 6AU6 oscillator in X6 with a 1 3/4" shield.
  - c. A 6AU6 speech amplifier in X1 with a 1 3/4" shield.
  - d. A 6AU6 audio driver in X2 with a 1 3/4" shield.
  - e. The 6AL5 bias rectifier in X11, no shield
  - f. The 5V4G L.V. rectifier in X10.
  - g. Two 5R4GY H.V. rectifiers in X8 and X9.
  - h. Two 807 modulators in X3 and X4, connect plate caps.
  - i. The 6146s in X7 and X17 attach plate caps.
  - j. The 6AQ5 screen voltage regulator into X28.
  - k. The 6J6 audio limiter, V70, into X70.
  - l. Turn the shaft of the 6AQ5 bias control R30 to its full counter-clockwise position.

The Viking II CDC should now be ready for its initial operation but do not attempt to turn it on until the Tuneup section has been studied.



### C. VIKING II CDC TUNING DETAILS

1. TYPICAL TUNING: 5.8 to 8.4 mc tuneup procedure will serve to acquaint the operator with the usual steps involved. Deviations of procedure for other bands will follow.
  - a. Connect a good ground wire or counterpoise to the ground terminal at the rear of the chassis. If there is some question of ground effectiveness read the section "How to Obtain a Good Ground" under the Pi Network tuning and Harmonic Suppression topic on page . Connect an antenna or dummy load (a 100 watt light bulb may be used with appropriate leads) to the output receptacle at the rear middle of the chassis.
  - b. Plug in a 5.8 to 8.4 mc crystal in position 1 of the crystal selector socket. 2.9 to 4.2 mc crystals are usually very satisfactory.
  - c. Set the "crystal" dial on "0".
  - d. "Freq" on 5.8 - 8.4.
  - e. "Drive" on "0".
  - f. "Final" (larger spinner knob) on "0" (Full tank in).
  - g. "CW-phone" on "cw".
  - h. "Plt" (High voltage) bat handle switch off (down).
  - i. "Coupling" on "1".
  - j. "Fine Coupling" on "0".
  - k. Auxiliary switch on "3.5 - 30".
  - l. Approximate settings of the oscillator and buffer may be obtained from tuning curves on the sheet following page 10.
  - m. Throw "fil" switch SW1 on (up). This applies all voltages except plate and screen voltages for the 6146 final and 807 modulators.
  - n. Turn "Crystal" switch to position 1. The "osc" current should drop perceptibly.
  - o. Turn "meter" to "bfr" and advance "drive" to about position 3 in the clockwise direction.
  - p. Tune "oscillator" slowly for a rise in buffer current. Adjust tuning for maximum buffer current. In some cases a slight dip of buffer current may occur between two maximum current points. This is true with very active crystals or a strong 6AU6 oscillator tube. Correct tuning, when this occurs, is usually on the dip between the maximum points.
  - q. Turn meter to "grid" and note 6146 grid current. If it should be over 8 ma, reduce it at once by turning "drive" counter-clockwise. Usually there would be no grid current at this point but the buffer tuning could happen to be nearly correct.

1. r. Tune "buffer" for maximum grid current keeping the grid reading below 8 ma by means of the "drive" control. After "buffer" has been properly adjusted, turn "drive" to its 0 position.
- s. Turn meter to "plt" position and "plate" on. Turn "drive" clockwise until plate current rises to 100 ma.
- t. Tune "final" toward 100 until plate current dips sharply. Be certain that the final is tuned to the first dip in plate current thus assuring that the amplifier is tuned to the fundamental and not to a harmonic.
- u. Turn meter to "grid", and touch up buffer tuning for maximum grid current. Advance "drive" until 6 ma of grid current is obtained. Turn meter to "plt".
- v. Proceed to load the antenna or dummy load by advancing the coupling control toward higher numbers, retuning the "final" for a dip after each adjustment of the coupling control. Continue this procedure, adjusting coupling control and retuning final, until a meter reading of approximately 200 ma. is obtained under resonant conditions (final dipped).
- w. A minimum coupling capacity equivalent to that of position "6" of "coupling" should be maintained in any case on the 5.8 - 8.4 mc range. The antenna is usually of the range of the Viking II CDC if less than a total of 150 mmfd of output capacity is required on this range. If "coupling" is turned to 7, "fine coupling" should be advanced no further than 60 in the following step x.
- x. Turn "fine coupling" toward higher numbers until the "plt" reading rises to about 250. Dip the plate current with "final" adjustment again and follow this procedure until a desired plate current between 250 and 300 ma has been reached. If the desired coupling cannot be obtained with the "coupling" setting of step w, turn the "fine coupling" to 0 and advance "coupling" another step and readjust "final" and "fine coupling". "Plate" current on CW should not exceed 300 ma.

The preceding steps complete the normal tuning procedure. However, when initially setting up the equipment the 6AQ5 clamper tube must be adjusted and once adjusted will remain stable and need not be changed over long periods of time.

## 2. CLAMPER TUBE ADJUSTMENT

- a. Turn the shaft of the 6AQ5 bias control R30 to its full counter-clockwise position.
- b. Loosen the tap on the voltage divider R13 completely and adjust its position to between 1 3/4 and 2 inches from the rear end terminal (if not already adjusted).
- c. Switch to the phone position. Decrease the amplifier loading to 230 ma "plt" current by means of the coupling controls, bringing the amplifier back to resonance (minimum "plt" current) by means of the main tuning dial ("final") after each coupling adjustment. Reset the drive control for 6 ma grid current when the plate current is exactly 230 ma.

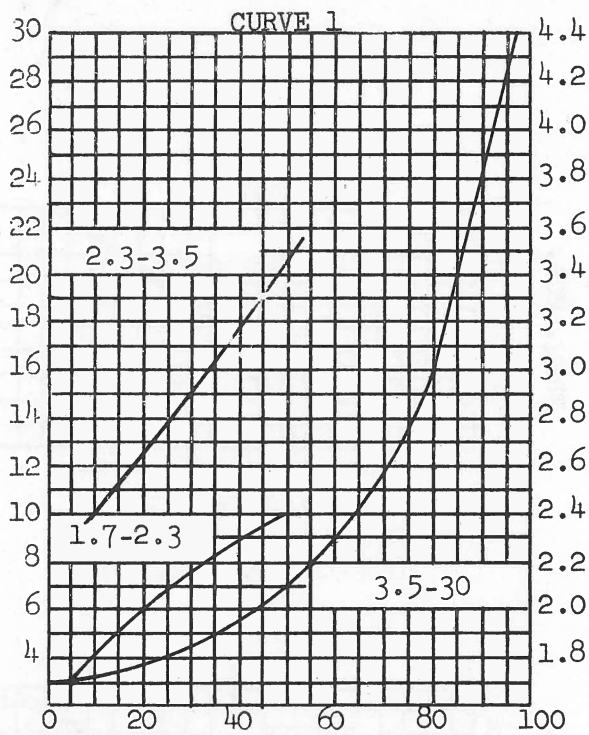

FINAL DIAL SETTING  
FINAL AMPLIFIER TUNING CALIBRATION  
VIKING II-CDC TRANSMITTER

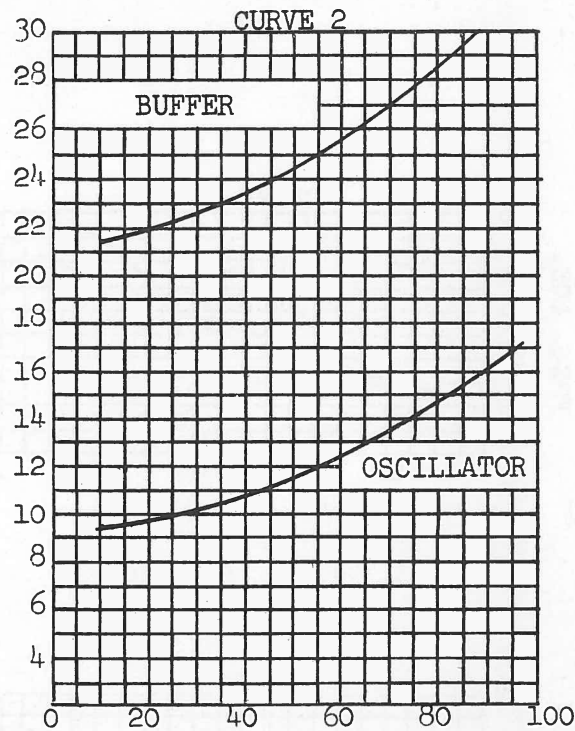

DIAL SETTINGS  
EXCITER CALIBRATION 23-30 MC  
BANDSWITCH POSITION  
VIKING II-CDC TRANSMITTER

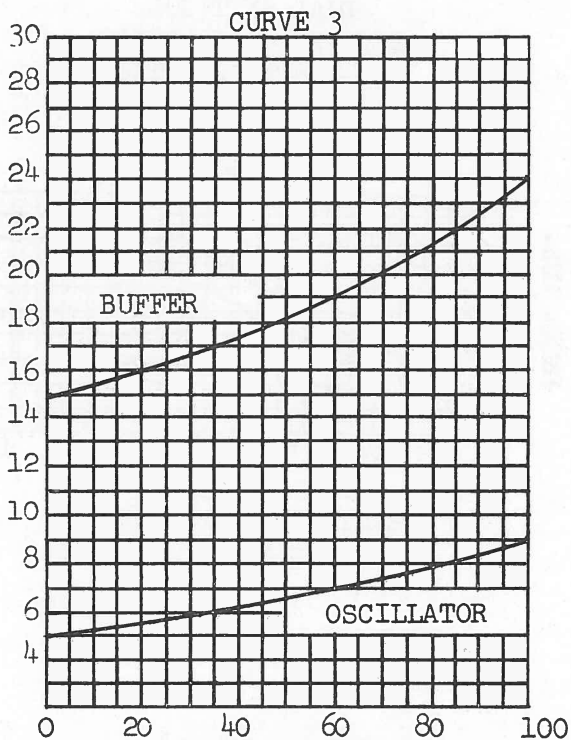

DIAL SETTINGS  
EXCITER CALIBRATION  
16.6-23 MC POSITION

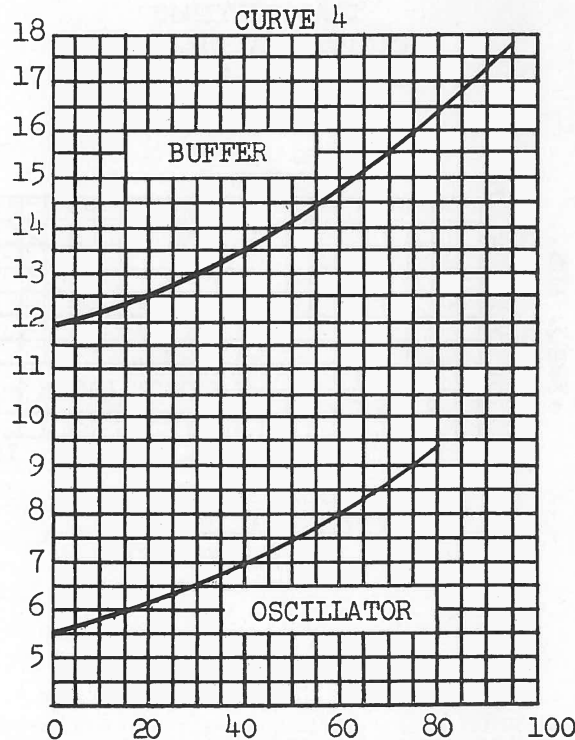

DIAL SETTINGS  
EXCITER CALIBRATION  
11.7-16.6 MC POSITION

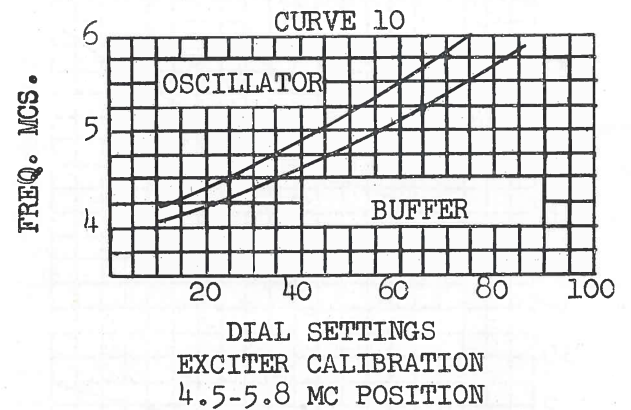
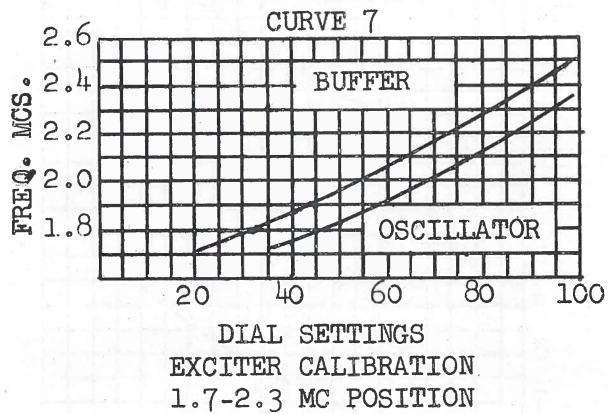
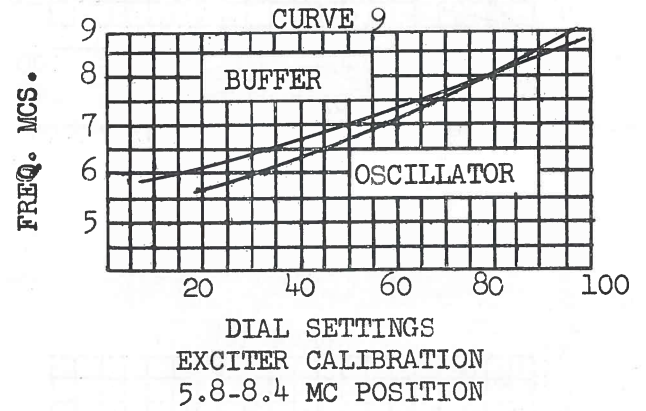
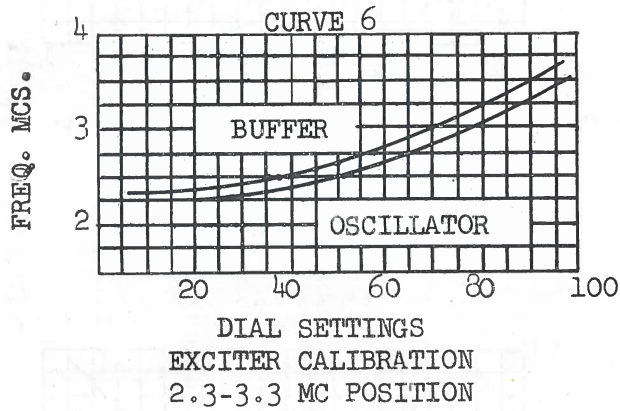
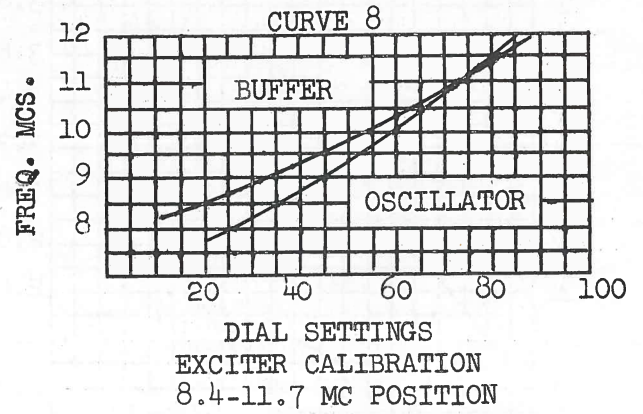
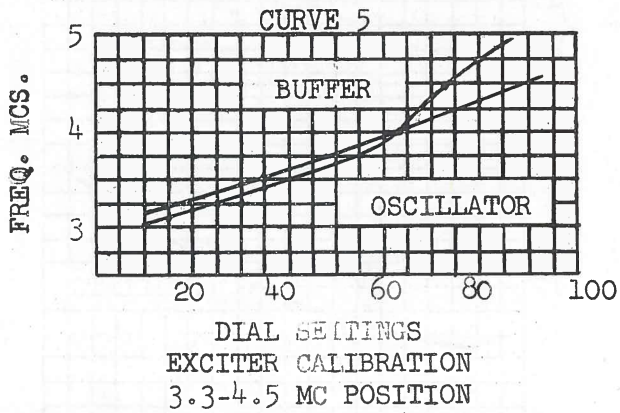

2. d. Now note the modulator cathode current with the audio gain control in the counter-clockwise position. This current should be between 60 and 80 ma. If the modulator current is less than 60 ma., loosen the tap on R13 (REMOVE ALL VOLTAGES FIRST) and move it toward the rear about 1/8" at a time. If the current is more than 80 ma. move the tap toward the panel.
- e. After having established the modulator current between 60 and 80 ma., with grid current at 6 ma, "Plate" current at 230 ma., switch the high voltage off, switch to the CW position. Turn R30 to its full clockwise position, tune "crystal" switch to "0", turn on the high voltage.
- f. BE CAREFUL AT THIS POINT SINCE FULL VOLTAGE IS APPLIED! AN INSULATED SCREW DRIVER IS RECOMMENDED FOR THIS ADJUSTMENT. It is also advisable to keep one hand away from the equipment by holding arm behind your back or hand in pocket. It may seem overly cautious but it can save your life. Switch the meter to read plate current. Turn R30 in a counter-clockwise direction until current rises perceptibly, adjust to 10 ma., the first mark on the meter scale above zero.
- g. Switch back to the phone position. Amplifier "plate" current should be less than 50 ma. Turn off high voltage, set the crystal switch to the desired crystal position.
- h. This completes adjustment of the clamper tube. This adjustment should remain stable over long periods and need not be changed even though the line voltage varies widely.

CW OPERATION may now be carried on by simply plugging in the key. If keying is slightly erratic, retune the "oscillator" slightly until keying is crisp and clean. For CW operation the final (power) amplifier may be loaded to any "plt" current up to 300 ma. For phone operation "Plt" current should be limited to 230 ma.

3. 1.7 - 2.3 MC TUNING: Proceed as described with the following exceptions:
  - a. Auxiliary switch on "1.7 - 2.3 mc" (do not turn unless "plate" is off).
  - b. Use 1.7 to 2.3 mc crystals in crystal socket position corresponding to "crystal" settings.
  - c. Final tuning will be very broad. With high impedance antennas the "final" may be against the stop on the "0" end when resonance is indicated. In this case leave the main dial at "0" and advance "coupling" toward higher numbers. Do not advance "coupling" beyond 6 and "fine coupling" beyond 50 in any case. A further reduction in output capacity indicates that the antenna terminal impedance is out of the range of the transmitter. Although you may feel the tank is out of resonance, the circuit is so broad that good resonance conditions still exist and its efficiency is not impaired.
4. 2.3 to 3.3 MC TUNING
  - a. AUXILIARY switch on "2.3 to 3.5" (Plate "off" while changing).
  - b. Use 2.3 to 3.3 mc. crystals.

4. c. Do not attempt to use "coupling" beyond step 6, or "fine coupling" beyond 50 in cases of high antenna impedance as in the case of 1.7 to 2.3 mc. tuning.
5. 3.3 - 4.5 MC TUNING:
  - a. AUXILIARY switch on "3.5 - 30 mc" (plate "off" while changing).
  - b. Use 1.65 to 2.25 mc or 3.3 to 4.5 mc crystals.
  - c. Do not attempt to use "coupling" beyond step 6 or "fine coupling" beyond 50 in cases of high antenna impedance as in the case of 2.3 - 3.3 mc tuning.
6. 4.5 to 5.8 MC TUNING:
  - a. AUXILIARY switch on "3.5 to 30" (plate "off" while changing).
  - b. Use 4.5 to 5.8 mc or 2.25 to 2.9 mc crystals.
  - c. Do not attempt to use "coupling" beyond step 6, or "fine coupling" beyond 50 in cases of high antenna impedance as in the case of 3.3 to 4.5 mc tuning.
7. 5.8 to 8.4 and 8.4 to 11.7 MC TUNING:
  - a. AUXILIARY switch on "3.5 to 30" (plate "off" while changing).
  - b. Proceed as in previous steps.
8. 11.7 - 16.6 MC TUNING:
  - a. 5.85 to 8.3 mc crystals may be used.
  - b. In nearly all cases the "coupling" switch can be set a 7 and loading accomplished by "fine coupling" alone. The "fine coupling" should never be advanced beyond a setting of 70 for this range with "coupling" at 7.
9. 16.6 - 23 MC TUNING:
  - a. 5.5 to 8.4 mc crystals are preferred.
  - b. Set "coupling" at 7. The "fine coupling" control should never be advanced beyond 80 in any case.
10. 23 - 30 MC TUNING:
  - a. 5.75 to 7.5 mc crystals are recommended.
  - b. Set "coupling" at 7. Do not advance "fine coupling" beyond 90.
  - c. Touch up tuning. Final will have setting near 100.
- 10A. If difficulty is experienced in obtaining a "grid" indication on the 16.6 - 25 or 25 - 30 mc due to weak crystal activity or double peaks on buffer current tuning, the "plt" current may be used to determine the initial settings as follows (this procedure is rarely needed as the Viking is normally very easy to tune on these bands):

- 10A. a. Turn oscillator stage as usual for maximum buffer current.
- b. Turn "drive" to 0.
- c. Turn "meter" to "plt."
- d. Turn "plate" switch on.
- e. Turn "driver" up to about 4 while watching the plate current.
- f. Tune buffer and oscillator for maximum plate current, limiting the "plt" reading to 100 ma by means of the "drive" control during tuning. Do not leave "plate" on while final is untuned for periods of more than 30 seconds.
- g. Turn "plate" switch off and check "grid" current. Log settings if difficulty is anticipated in retuning under the same conditions:

11. PHONE OPERATION:

- a. Tune up Viking II CDC in "cw" position.
- b. Turn the "plate" switch off.
- c. Turn "phone-cw" switch to "phone" turn plate switch on, adjust for 6 ma grid current, 230 ma. "plt" current (Plate current should not exceed 230 ma for phone operation). Turn plate switch off.
- d. Turn "audio" to "0" and connect a high impedance crystal or high output dynamic microphone to the connector marked "mic".
- e. Turn meter switch to "mod". Turn plate switch on. The modulator no signal current should be between 60 to 80 ma.
- f. Place a D.C. volt meter between jack J70 and ground to read positive voltage and adjust R76 for a plus four (4) volt reading. This completes the modulation limiter adjustment.
- g. Talking into the microphone, advance audio until the "mod" current rises to 120 to 130 ma on audio peaks. 120 to 130 ma. of modulator current corresponds to 100% modulation. A small downward reading of "plt" is normal during modulation.
- h. Check 6AQ5 clamper tube adjustment by switching crystal out of the oscillator circuit momentarily. "Plate" current should drop to less than 50 ma.

If plt current is above 50 ma, refer to clamper tube adjustment section C,2 (page 10).

12. VFO OPERATION:

- a. Review the discussion of VFO excitation under "Theory of Operation".
- b. Plug the VFO output cable into the VFO coax receptacle at the left rear of the Viking II CDC chassis. A 50 to 150 mmfd isolating condenser may be needed in the center conductor of the connection cable to prevent the 6AU6 grid from being short circuited if the VFO output has a continuous D.C. path to ground. (The isolating capacity is unnecessary when the Viking VFO is used.)

12. c. Use the VFO in the same manner as crystals are used for output on the band selected. Only two volts of signal at the Viking II CDC 6AU6 grid will drive the transmitter to full output on 1.7 - 4.5 mc. Six volts of VFO excitation at the 6AU6 grid will be sufficient to drive the Viking II CDC to full output on all bands, 5.8 - 30 mc. The RF Voltage at the 6AU6 grid should be limited to value of less than 15 to 20 volts to prevent the stage from blocking.
- d. It should be borne in mind that any tendency of the VFO to chirp or drift is multiplied when the transmitter's output frequency is two, three, or four times the VFO output.
- e. Zero beating a received signal in cw operation is accomplished by simply closing the key (with "plate" off) and adjusting the VFO for a zero beat with the received signal in the receiver. If the coupling of the Viking II CDC exciter stages to the receiver is so close that the receiver tends to block, the exciter stage can be disconnected from the VFO by tuning the "crystal" switch to the #5 or #6 vacant crystal positions while adjusting the VFO. (Enough VFO coupling takes place in the #1 and #2 positions to partially excite the 6AU6.)
- f. Zero beating signals in phone operation is done by tuning the "phone-cw" switch to "cw" and proceeding as described previously. In cases of very weak signals the receiver BFO may aid in making the VFO zero beat setting.

#### D. VIKING II CDC PI-NETWORK TUNING AND HARMONIC SUPPRESSION

The pi tuning/coupling network in the Viking II CDC is designed to load the final amplifier into antenna resistances of nominally 50 to 600 ohms throughout the frequency range of the transmitter. In addition, it is capable of "tuning out" series antenna reactances up to several hundred ohms to complete a good match to most unbalanced antenna systems. The range of antenna impedances which may be matched by the pi network at frequencies higher than 7.0 mcs. extends from roughly 25 to 2000 ohms

When the transmitter is well grounded and properly tuned, the higher harmonic suppression is excellent, generally much better than with other conventional methods of antenna coupling. This should be of interest to amateurs afflicted with TVI or other high frequency interference problems.

##### 1. Importance of grounding:

To obtain proper tuning, coupling, and harmonic suppression with any transmitter antenna coupling system, the part of the circuit designed to operate at RF ground potential must be at RF ground potential. A "room full of RF" is evidence that a high RF potential exists on something in or near the room. In many cases the source of RF is the transmitter's chassis and power cord. This condition is very undesirable for several reasons. The power cord is very closely coupled to the chassis by the electrostatic shields of the power transformers. Three objectional factors which obviously affect the loading of the transmitter when poor grounds are involved are:

- a. The impedance that the output terminal of the transmitter looks into includes not only the true antenna to ground impedance as presented by the antenna feed-line but also the transmitter chassis to ground impedance. This additional impedance in some cases will raise the apparent antenna impedance to such a high value that it cannot be loaded by the pi network.



1. b. Part of the transmitter's power is lost in the ground system due to radiation of the ground lead, power cord or cabinet. This power is quickly dissipated in surrounding objects and contributes nothing to effective radiated power except to distort the antenna's normal field pattern.
  - c. It is conventional, in designing a transmitter, to bypass harmonics or any possible sources of stray high frequency currents to the chassis on the assumption the chassis will be kept as near ground potential as possible. When a high impedance is presented to these currents at the chassis they are able to radiate to some extent rather than be passed harmlessly to ground.
2. How to Obtain a Good Ground:

What may appear to be a good ground at one frequency may prove to be a poor ground at another. A single ground lead may have "standing waves" on it due to its length. While it may seem difficult to obtain a good ground over a wide range of frequencies, it can be done and will be well-worth the trouble when increased radiation efficiency, ease of antenna loading and reduced TVI and BCI result. There is also reduced danger of damaging microphones, receivers and other associated equipment with excessive RF fields.

Avoid using the power line, power line conduit or gas lines for RF grounding. Some suggestions which may help to obtain a good ground are:

- a. Water pipes or metal building structural members are usually good sources of earth grounds.
- b. Use heavy conductors (#14 or larger) between the connection at the ground point and the transmitter. Copper ribbon is excellent for this purpose.
- c. The use of several leads, each of a different length and selected at random may be helpful in keeping grounding impedance low at the transmitter, even though the transmitter is some distance from a true earth ground. The possibility of obtaining an effective ground at any frequency throughout the transmitter's range is quite good. If at any one frequency, one of the ground leads presents a low impedance at the chassis, the chassis is effectively grounded. By changing the length of one of the ground leads experimentally a good ground can often be obtained at a frequency which has been troublesome. In bringing several leads to the transmitter, small closed loops near the transmitter or antenna feed line should be avoided. Induction fields will tend to raise the impedance of the ground leads.
- d. In cases where it is impossible to obtain a good earth ground, connecting the transmitter chassis to some system of conductors having a very low effective impedance to ground compared to the antenna impedance may be helpful. Usually this artificial "ground" takes the form of a system of radial wires spread horizontally on the floor, a gridwork of wires, or a large metal sheet on the floor below the transmitter. To be most effective, the minimum area covered by the metal conductors should be roughly equivalent to a square, the length of one side of which approaches a quarter wavelength. This system of "grounding" should be experimented with before committing the location to any permanent installation.
- e. A simple counterpoise made up of a single wire attached to the chassis may be helpful. One 23 - 30 mc a length of 6 to 8 feet may be attached and the open end cut off 4 inches at a time until the chassis becomes "cold". The

- e. open wire may be allowed to drop along the floor although its open end will be somewhat "hot".
- f. A rough check on the effectiveness of the transmitter ground may be made by touching the chassis while watching the PA plate current and grid current with the transmitter operating into an antenna. A change in current upon touching the chassis is indicative of an ineffective ground. If a neon bulb, held between the fingers, can be ignited by touching it to the chassis, the RF present is excessive and is another indication of an ineffective ground. In cases where the transmitter is feeding a low impedance antenna, the test by touching the chassis is more reliable since 50 to 60 volts is required to ignite the neon lamp.

### 3 Loading Random Antennas with the Pi Network:

With the transmitter chassis well grounded, correctly designed antenna systems having relatively "flat" unbalanced feeder systems, can easily be loaded by following the instructions already given, provided the antenna terminal impedances fall within the range of the pi network. Feeding a balanced system with a feedline over a quarter of one wavelength long, may prove to be surprisingly successful if the transmitter chassis is held at ground potential. The transmission line between the transmitter and antenna will tend to assume a partial balance at the antenna. Some standing waves will result but may not be excessive. The Johnson Matchbox, a universal all band, bandswitched antenna coupler will permit loading of the Viking II CDC transmitter to any practical antenna system. In addition, it provides for the use of the Johnson 250-20 Low Pass Filter for increased harmonic suppression.

Antennas having random lengths, random feed points and various types of feed lines will exhibit widely different resistance and reactance characteristics. It is well to remember that the feedline is a very important part of the system. A common example of the random antenna is a horizontal wire fed by a single wire feed line. The feedline in this case actually becomes part of the radiating system. An antenna of this type can, in most instances, be fed by the pi network directly but there are critical dimensions where the antenna series reactance (inductive or capacitive) becomes too high and the antenna resistance can become either too high or too low to be matched by the pi network.

Antennas with high terminal resistance or reactance can usually be recognized while loading the final stage of the Viking II CDC. The final amplifier is normally loaded by reducing the output coupling capacitor (C30) in small steps, retuning the amplifier to resonance each time. This results in an increase in PA cathode (plt) current and is continued until full loading is achieved. If, however, a point is reached where decreasing the output coupling capacitor (C30) does not result in a marked increase in PA cathode (plt) current and the PA is not fully loaded, the antenna can be assumed to have a high resistance at this frequency.

Antennas with low terminal impedance (resistance and reactance both low) can usually be recognized by a noticeable lack of coupling condenser effect in the range of settings normally used at the operating frequency. There will be little or no detuning evidenced as the coupling control is changed.

Several things can be tried in an effort to bring the antenna system into the tuning range of the pi network:

- a. Change the length of the feeder line between the antenna and transmitter experimentally  $1/8$  to  $1/4$  wavelength.
- b. Change the point of connection of the feedline to the antenna  $1/8$  to  $1/4$  wavelength.
- c. Change the antenna length  $1/8$  to  $1/4$  wavelength. Antennas shorter than  $1/8$  wavelength (antenna and feeder) may be difficult to load. They present a high capacitive reactance to the transmitter output terminals. Effective antenna lengths in the vicinity of  $1/2$  wavelength will in general exhibit characteristics of high resistance, high reactance (inductive or capacitive) or both.
- d. "Load" the antenna feeder by placing an inductor or capacitor in series to cancel out the reactance of the antenna feeder. This may require considerable cut and try and will affect only the reactive component of the antenna impedance. However, it can prove useful in some cases.
- e. L type matching networks of inductance and capacitance may be used to aid impedance matching. Much discussion of this more elaborate method of bringing the impedance within the range of the pi network could be included, however, the few cases where it is necessary do not justify inclusion herein. Textbook and handbook discussions will be helpful if work along this line is pursued. There is danger of resonating the coupling condenser of the pi network when using an external coil. This should be watched as excessive voltage built up across the coupling condensers can cause damage. Improper coupling or loading will take place under these conditions.

4. Dangers to be avoided and hints which may further aid in harmonic and TVI reduction.

- a. When loading high impedance antennas there is a temptation to "squeeze" the last watt into the antenna by opening the coupling condensers as much as possible. Harmonic suppression is dependent, to a great extent, on the amount of coupling capacity in the circuit. It is wise to use as much coupling capacity as practical at all times. The proper amount of coupling when the antenna impedance is high, can be conveniently determined by holding a neon lamp against the antenna feeder. The coupling condenser can then be opened until little increase in glow is noticed when the coupling condenser and tuning controls are adjusted for maximum output. A decrease in coupling capacitance beyond this point may cause a higher plate current reading due to reduced plate circuit efficiency. Higher harmonic output will also result as the coupling capacity is reduced beyond the point where the output has leveled off. The random antenna system may present a more favorable impedance to harmonic output than the output on the fundamental frequency; hence it is well to use as much coupling capacity as is practical. It is well to remember that the amount of coupling capacitance needed is dependent on the operating frequency. For example, 2,000 micro microfarads at 3.5 mcs corresponds to 160 micro microfarads at 28.0 mcs. These are the values necessary to couple resistive loads of approximately 50 ohms, at the frequencies stated.
- b. The low frequency bands may present the danger of doubling in the final stage when the antenna impedance is high. If the coupling condensers are reduced to values comparable to the capacity of the tuning condenser (C29) the net plate tuning capacity is reduced, as these condensers are effectively in series, and it becomes very possible to inadvertently tune to the second harmonic

4. b. instead of the fundamental of the intended output frequency. To avoid doubling in the final, the initial tuning should be done with all the output coupling capacity in the circuit and the final tuning control starting from its zero setting. The first dip of the amplifier cathode current, as the tuning control is advanced from zero setting is the resonant point for the fundamental output frequency. As the coupling condensers are reduced the tuning control should be reset, toward zero, for minimum cathode current so that the original plate circuit resonant frequency is maintained. Avoid reducing the coupling condenser values below the point where the output levels off as discussed previously. No danger of doubling in the final will occur if the proper tuning method is followed. For some high impedance coupling conditions on the low frequency end of the 1.7 - 2.3 mc band, much of the output coupling capacity may be out of the circuit as the antenna is loaded and the tuning control may approach the maximum tank capacity setting (dial zero) and tend to go beyond. The amplifier is quite broad here and if, under these conditions, the tuning control is left at zero, the output coupling capacity has been reduced excessively, and the efficiency will be quite good.
- c. If the power line voltage is low or the high voltage rectifiers have low emission, the loaded plate current may not reach the normal value. This condition should not be confused with the inability of the pi network to load an antenna system.

5. Coupling to Balanced Antennas:

Balanced antennas such as center fed "Zepps", beams and folded dipoles normally use a two wire transmission line and should have equal voltages, 180 degrees out of phase, applied to each feedline terminal. Since the output of the Viking II CDC is single ended, unbalanced, a coupler is required for balanced antenna systems. The Johnson Matchbox, a universal all band, bandswitched antenna coupler will permit loading of the Viking II CDC Transmitter to any practical antenna system. In addition, it provides for the use of the Johnson 250-20 Low Pass Filter for increased harmonic suppression. A simple coupler for this purpose is shown below. The tank circuit is resonant at the operating frequency and can be excited by a coaxial line and coupling link. Line impedance is not critical although 52 ohm line will be most desirable if a JOHNSON Low Pass Filter is to be used.

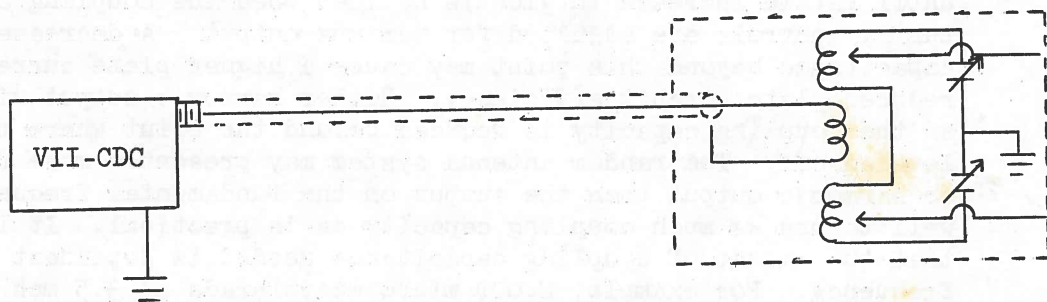

Feedpoint impedance of the coupler is adjusted by means of the inductor taps. Tap adjustment unnecessary with Johnson Matchbox. Final amplifier loading is adjusted with the transmitter output coupling controls.

Tuning of the coupler can be made quite broad by making the L/C ratio as high as possible (low "Q") while still permitting the desired loading. Inductive reactance of the coupling link may make it impossible to reduce the SWR of the coaxial line to or below 1 1/2 to 1. If so, the link circuit may be made series resonant by adding capacitor C1 as shown on following page.

5.

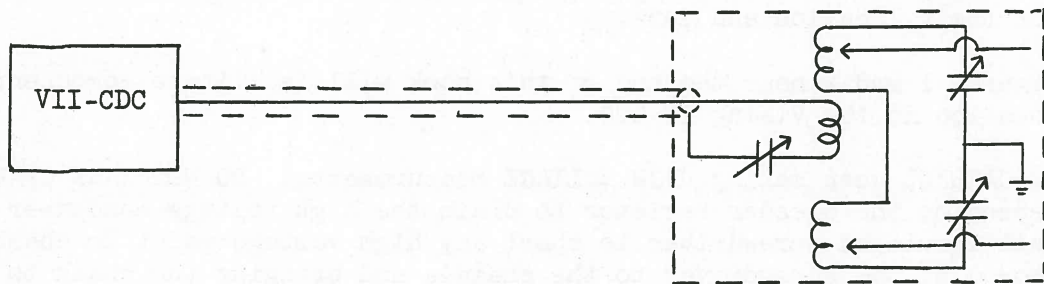

#### 6. Use of Low Pass Filters:

Depending upon how it is tuned, 2nd harmonic attenuation of the Viking II CDC amplifier can be as high as 30 db. Since this will permit operation in many locations without television interference, the JOHNSON 250-20 Low Pass Filter is not an integral component of the Viking II CDC but is available as an optional accessory. This filter will provide an additional 75 db or more harmonic attenuation with insertion loss less than .25 db. Characteristic impedance is 52 ohms, power rating 1 KW.

The Low Pass Filter may be inserted in the coaxial line between the transmitter and the antenna coupler. Coaxial connectors are used at the transmitter and at both ends of the Low Pass Filter to preserve the shielding provided by the coaxial line. It is important that the standing wave ratio on the coaxial line be maintained at 1 1/2 to 1 or less, therefore the impedance of the line between the Viking and the coupling link should be the same as the characteristic impedance of the filter. (The JOHNSON 250-20 Low Pass Filter and JOHNSON Matchbox are 52 ohms impedance.) The section of coaxial line between the transmitter and the Low Pass Filter should be as short as possible and electrical quarter waves should be avoided. An RF bridge such as the Johnson 250-20, for measuring SWR will prove invaluable for initial set-up and for operational checks.

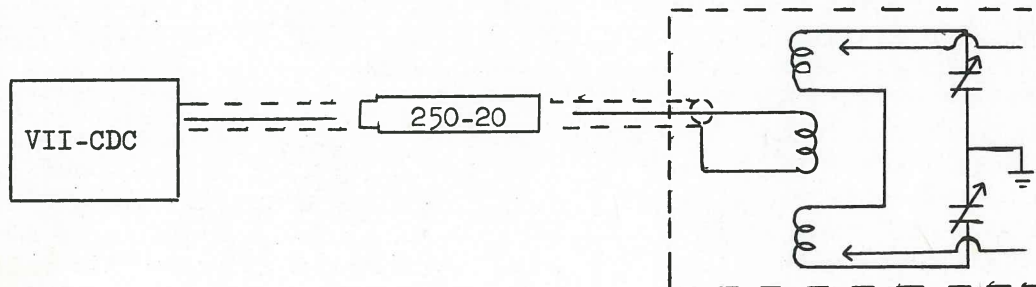

An end fed half wave antenna may present loading problems, both from the standpoint that its impedance is higher than can be matched by the pi-network amplifier of the Viking or that the low output coupling capacitance used reduces inherent harmonic attenuation below tolerable values. Therefore the use of a half wave antenna may create TVI problems while other antennas prove perfectly satisfactory. In these cases it is recommended that the JOHNSON Matchbox be used.

#### E. TROUBLE SHOOTING

1. SCHEMATICS, PHOTOGRAPHS, AND CHARTS aid greatly in trouble shooting; use them. Part 2 and 3 list typical voltage, current and winding resistance values; in-

dividual transmitters may vary somewhat from the values shown but generally no more than 10 to 20%. Parts 4 through 13 list symptoms of trouble and suggestions for their location and cure.

Figures 1 and 2 near the end of this book will facilitate component and wire location in the Viking II-CDC.

BE CAREFUL when making HIGH VOLTAGE measurements. DO NOT TAKE CHANCES. Do not depend on the bleeder resistor to drain the high voltage condenser but use a well-insulated screwdriver to short any high voltage point to chassis by first grounding the screwdriver to the chassis and bringing the shank to the terminal to be discharged.

All power supplies must be off and discharged before making ohmmeter measurements.

2. Typical Viking II-CDC voltages and currents with the 6146 Final loaded into a 50 ohm load:

a. CW operation 115V 60 cycle AC, input voltage measurements made with 20,000 ohm/volt voltmeter.

Frequency 28.868

|  |                                     |
|--|-------------------------------------|
| P.A. screen and plate current ("plt")            | 300 ma                              |
| P.A. grid current ("grid")                       | 6.0 ma                              |
| P.A. plate voltage                               | +660V                               |
| P.A. screen voltage                              | +175                                |
| P.A. grid bias (total)                           | -97 V (-77 no sig)                  |
| Power output                                     | 135 watts                           |
| Buffer current                                   | 20 ma                               |
| Oscillator current                               | 8.0 ma                              |
| Low voltage B+                                   | +310V                               |
| Bias Supply Voltage                              | -80V(with 6.0 ma 6146 grid current) |
| 6AQ5 fixed bias                                  | -25 V "                             |
| 807 fixed bias                                   | -37 V "                             |
| 6AU6 speech amplifier (socket X1) screen voltage | +70 V (no sig)                      |
| 6AU6 speech amplifier plate voltage              | +60 V "                             |
| 6AU6 audio driver (socket 2) screen voltage      | +180 V "                            |
| 6AU6 audio driver (socket 2) plate voltage       | +300 V "                            |

b. Phone operation with the above input conditions. Only readings which vary significantly from CW operation or apply only to phone operation are recorded. Approximately 30% modulation was applied during measurements.

|                               |   |
|-------------------------------|---|
| P.A. screen and plate current | 230 ma  |
| P.A. plate voltage            | +620 V  |
| P.A. screen voltage           | +185 V  |
| Power output                  | 110 watts (carrier and side bands)<br>102 watts (no signal) |

Modulator cathode current

90 ma (75 ma no signal)

The no signal "mod" current should be between 60 to 80 ma. This may be adjusted by moving the tap nearest the rear of the chassis on the high voltage divider R13. (WITH POWER OFF) If the R13 tap is adjusted, R30 should be readjusted.

3. Transformer and choke winding resistances and open circuit voltages.

| <u>Winding</u>      | <u>Color of Leads</u> | <u>Resistance</u> | <u>Open ckt AC voltage</u>  |
|---------------------|-----------------------|-------------------|---|
| T1 P1781 115 V pri. | Black to Black        | 1.0 ohms          | (112 V 60 cy input)   |
| secondary           | red to yel-red        | 105               | 865 volts   |
|                     | yel-red to other      | 96                | 865   |
| T2 P1893 115 V pr.  | black to black        | 2.5               | ---   |
| L.V. sec.           | red to yel-red        | 97                | 298   |
|                     | yel-red to other      | 95                | 298   |
| Bias sec.           | blue to blue          | 46                | 140   |
| Fil                 | green to green        | less than .1      | 6.4   |
| L.V. rect.          | brown to brown        | .2                | 5.1   |
| H.V. rect.          | yel to yel            | .1                | 5.2   |
| L1 P1783 H.V. choke |                       | 95                |   |
| L2 P1501 L.V. choke |                       | 280               |   |
| L3 P1784 Bias Choke |                       | 440               | Open circuit<br>1000 cycle inductance   |
| T3 P1503 Audio pri. | red to blue           | 210               | approx. 2.6 H   |
| sec.                | black to yel          | 110               |   |
|                     | black to green        | 105               |   |
| T4 P1992 Mod. Pri.  | red to brown          | 100               | 1.5 to 1.75 H   |
|                     | red to blue           | 95                | 1.5 to 1.75 H   |
| Mod. sec.           | Gn-yel to green       | 36                | (.01 bypass condensers<br>C32 and C46 must be<br>disconnected before<br>measuring inductance) |

No attempt has been made to anticipate all troubles, operating errors, or component failure in parts 4 through 13, but a few symptoms with a discussion of probably causes may suggest means of analyzing other symptoms related to those mentioned.



## NEVER REPLACE FUSE WITH A VALUE HIGHER THAN 8 AMPERES

Under no circumstances should a Fusetron type fuse be used in this transmitter because of the high values of current that it will hold for long periods of time.

4. Fuse blows when "Fil" is turned on:
  - a. Check 6AL5, 5V4G, 6AU6's and 6AQ5 tubes for shorts between plate and other elements.
  - b. Look at tube socket terminals and T2 primary AC wiring for shorts.
  - c. The low voltage B+ may be shorted. An ohmmeter test of the exciter (oscillator or buffer) coils to chassis should show approximately 25,000 ohms.
  - d. If no short is found on the B+ line, check the transformer windings for shorts to ground or shorted turns. Open circuit voltage data may be useful in finding turn-to-turn shorts.
  - e. Check X10 wiring also shield of VFO power socket X12.
5. FUSE BLOWS when "plate" is turned on:
  - a. Check for condensed moisture on 5R4 sockets X8 and X9.
  - b. Check 5R4, 6146, and 807 tubes for shorts.
  - c. Check High Voltage B+ line for shorts (violet leads 42,43, and 44 may be conveniently isolated at the H.V. bleeder-divider resistor R13.)
  - d. Check H.V. primary wiring and "plate" indicator pilot light.
  - e. If no ground is found on H.V. B+ line, test H.V. transformer for shorts to ground or winding to winding.
6. R. F. EXCITER:
  - a. No "osc" current may be due to "cw-phone" switch on phone, key open, 6AU6 filament being open, or no L.V. B+.
  - b. "Grid" current low and "bfr" current low - may be due to a weak buffer or oscillator tube. A few 6AQ5's or 6AU6 may show good emission in a tube tester, but will prove to be poor R.F. amplifiers. Check tuning curves to be certain tuning is near the expected setting.
  - c. Key up "bfr" current being excessive may be caused by failures of the bias supply.
  - d. Erratic keying usually can be corrected by adjusting the "oscillator" tuning. If this does not correct the conditions the crystal may be suspected as normally the Viking keys cleanly with most crystals.

- e. Failure of oscillate is usually due to the crystal, but it may be well to check the position of the "crystal" dial to be certain it corresponds to the crystal socket number.
7. Inability to tune Final:
- a. Check position of AUXILIARY switch.
  - b. Check for loose connections in the tank and loading circuits.
8. Inability to load Final:
- a. Check ground connections.
  - b. Check antenna connections.
  - c. Read discussion on pi network loading.
9. Report of excessive harmonics:
- a. Check tuning to make certain doubling is not taking place in the final.
  - b. Examine antenna to make certain that its efficiency at the harmonic is not many times greater than at the fundamental.
  - c. Read discussion on Pi Network Tuning and Harmonic Suppression.
  - d. In checking harmonics, remember that an excessive fundamental signal to the receiver may cause harmonic generation in a receiver stage - hence a false indication may be noted.
10. Report of signals 20 to 60 KC away from either side of carrier:
- a. These spurious signals originate in the crystal. A few crystals will show some excitation near the fundamental mode of oscillation. Oscillation tuning may clear this condition in a few cases, but usually the crystal must be replaced.
11. R.F. on Chassis or Mike:
- a. Ineffective grounds or a very low impedance at the antenna termination at the transmitter may cause this - usually the former.
  - b. Read discussion on grounds in the pi network tuning discussion. Page 15.
  - c. R.F. pickup can result if an unshielded antenna lead-in is used with a high standing wave.
12. High 6146 "plt" current with key up:
- a. A fixed bias failure is indicated. Check 6AL5 tube.
  - b. Check bias voltage on second terminal from the rear of X21 (white wire)

- c. Check the resistance of the bias supply terminal to ground. This should be in the neighborhood of 5000 ohms.
  - d. Check adjustment of R30 and R13.
13. A squeal is heard on "phone":
- a. If a squeal or howl takes place when the audio is turned up, acoustical feedback between the mike and receiver may be the cause.
  - b. A microphone 6AU6 in the speech amplifier can originate a ringing or squealing noise.
  - c. A poorly shielded mike connection or lead can cause feed-back conditions.

THE UNIVERSITY OF CHICAGO LIBRARY

1950

1950

1950





## TUBE SOCKET CONNECTIONS BOTTOM VIEW

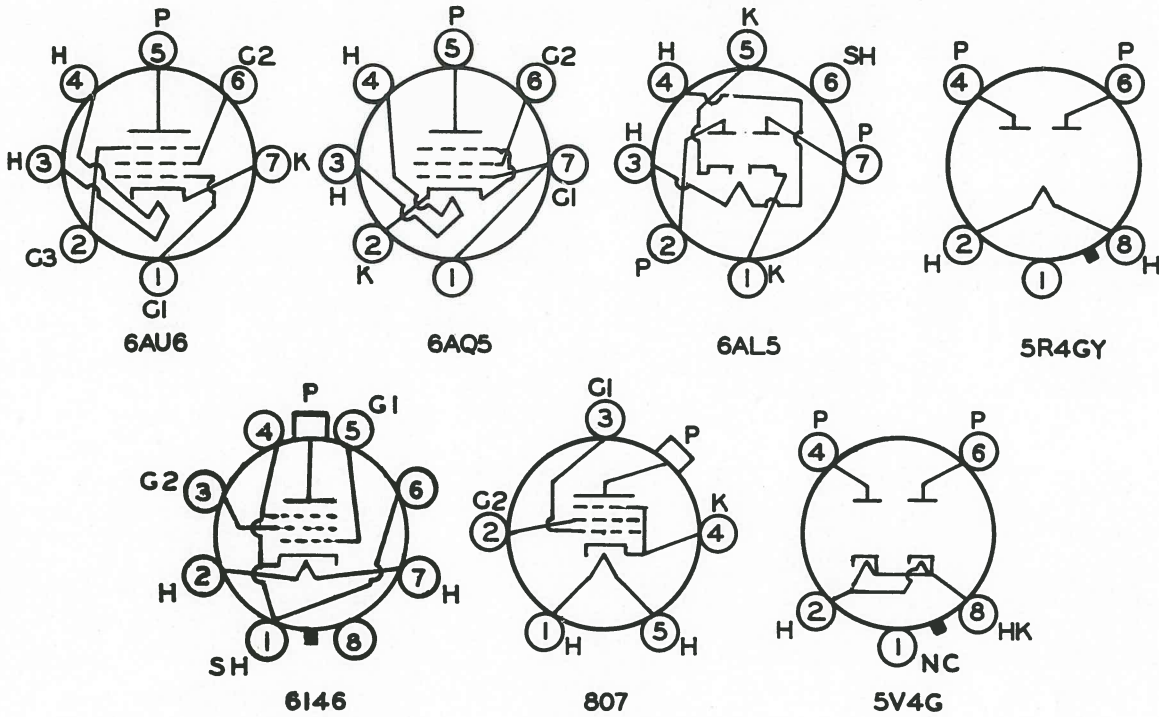

**P** PLATE  
**K** CATHODE  
**H** HEATER  
**SH** SHIELD OR SHELL  
**G1** CONTROL GRID  
**G2** SCREEN GRID  
**G3** SUPPRESSOR GRID

### Socket Connections

#### CONDENSER-RESISTOR COLOR CODE

| COLOR    | SIGNIFICANT FIGURE | DECIMAL MULTIPLIER | TOLERANCE (%) | VOLTAGE RATING# |
|----------|--------------------|--------------------|---------------|-----------------|
| BLACK    | 0                  | 1                  | 1             | 100             |
| BROWN    | 1                  | 10                 | 2             | 200             |
| RED      | 2                  | 100                | 3             | 300             |
| ORANGE   | 3                  | 1,000              | 4             | 400             |
| YELLOW   | 4                  | 10,000             | 5             | 500             |
| GREEN    | 5                  | 100,000            | 6             | 600             |
| BLUE     | 6                  | 1,000,000          | 7             | 700             |
| VIOLET   | 7                  | 10,000,000         | 8             | 800             |
| GRAY     | 8                  | 100,000,000        | 9             | 900             |
| WHITE    | 9                  | 1,000,000,000      | 5             | 1,000           |
| GOLD     | -                  | 0.1                | 10            | 2,000           |
| SILVER   | -                  | 0.01               | 20            | 500             |
| NO COLOR | -                  | -                  | -             | -               |

\* APPLIES TO CONDENSERS ONLY



#### COLOR CODING OF FIXED RESISTORS

**A**-FIRST SIGNIFICANT FIGURE OF RESISTANCE IN OHMS  
**B**-SECOND SIGNIFICANT FIGURE  
**C**-DECIMAL MULTIPLIER  
**D**-RESISTANCE TOLERANCE IN PERCENT. IF NO COLOR SHOWN TOLERANCE IS  $\pm 20\%$ .

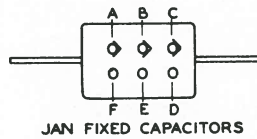

#### JAN FIXED CAPACITORS

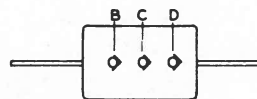

#### RMA 3-DOT CODE 500VOLT $\pm 20\%$

**COLOR CODING OF FIXED CONDENSERS**  
**A**-TYPE: MICA BLACK, PAPER SILVER  
**B**-FIRST SIGNIFICANT FIGURE OF CAPACITY  
**C**-SECOND SIGNIFICANT FIGURE  
**D**-DECIMAL MULTIPLIER  
**E**-TOLERANCE  
**F**-CHARACTERISTIC  
**G**-THIRD SIGNIFICANT FIGURE  
**H**-VOLTAGE RATING

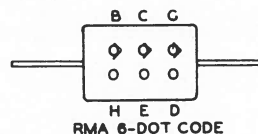

#### RMA 6-DOT CODE

### Resistor, Capacitor Color Code



FIGURE 1



FIGURE 2



FIGURE 3

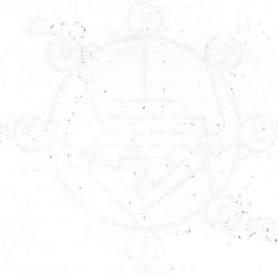

FIGURE 4



FIGURE 5



FIGURE 6



FIGURE 7

REFERENCES

1. J. D. ...

2. J. D. ...

3. J. D. ...

4. J. D. ...

5. J. D. ...

6. J. D. ...

7. J. D. ...

8. J. D. ...

9. J. D. ...

10. J. D. ...

11. J. D. ...

12. J. D. ...

13. J. D. ...

14. J. D. ...

15. J. D. ...

16. J. D. ...

17. J. D. ...

18. J. D. ...



# Viking II-CDC Transmitter

## Parts List

| <u>Part No. Or<br/>Drawing No.</u> | <u>Item<br/>No.</u> | <u>Qty.</u>          | <u>Description</u>  |
|------------------------------------|---------------------|----------------------|---|
| 17.810-2                           | CH2                 | 1                    | Chassis   |
| 17.811                             | CH3                 | 1                    | Final tube mounting plate                                   |
| 23.900-2                           | BKT1                | 1                    | Final Tuning Drive Assembly                                 |
| 17.754-2                           | BKT3                | 1                    | Bracket - Final Cond. Mounting                              |
| 17.752-1                           | BKT2                | 1                    | Bracket - Final Tank Support                                |
| 16.857-2                           | BKT4-7              | 4                    | Bracket - Crystal Sel. and Mounting                         |
| 16.1001-1                          | BKT8-12             | 5                    | Bracket - Component Mounting                                |
| 16.1044-2                          | BKT 13              | 2                    | Bracket - H.V. Filter Cond.                                 |
| 16.1089                            | BKT14               | 1                    | Tank Grounding Strap  |
| 16.1088                            | BKT15               | 1                    | Jumper Strap  |
| 16.82-17                           | BKT70               | 1                    | Rectifier Support Bracket                                   |
| 23.906-2                           | D1                  | 1                    | 0-100 Final Tuning Dial and Hub                             |
| 23.908-1                           | D2                  | 1                    | Final Tuning Index and Escutcheon<br>plate assembly         |
| 23.909                             | D3-6                | 4                    | Drive Pulley Hub Assembly                                   |
| 42.49-150                          | D7-8                | 8- $\frac{1}{2}$ ft. | Dial Cord   |
| 16.1027-1                          | D9-10               | 2                    | Dial Cord Tension Springs 9/16 x<br>3/16 x .033 Wire        |
| 14.145-7                           | D11                 | 1                    | $\frac{1}{4}$ " D NPB Shaft Extension 5 $\frac{1}{2}$ " lg. |
| 14.145-6                           | D13                 | 1                    | $\frac{1}{4}$ " D. NPB Shaft Extension 2 $\frac{1}{4}$ " lg |
| 115-256-15                         | D14                 | 1                    | Shaft and Bearing Assembly 1 5/8<br>length                  |
| 115-256-16                         | D15                 | 1                    | Shaft and Bearing Assembly 5 1/16<br>length                 |
| 104-250-51                         | D16                 | 1                    | Insulated Coupling  |
| 13.123-7                           | D17                 | 2                    | Panel Bearing   |
| 104-258                            | D18-19              | 2                    | Split Sleeve Coupling                                       |
| 23.910-2                           | K1                  | 1                    | Knob - Final Tuning   |
| 16.86-1                            | D20                 | 5                    | Tension Spring  |
| 23.907-12                          | K2-4                | 3                    | Knob Dial ( 100-0)  |
| 23.907-13                          | K5-7                | 3                    | Knob Dial (10-0)  |
| 23.907-14                          | K8,9,12             | 3                    | Knob Dial (single marker)                                   |
| 23.907-17                          | K10                 | 1                    | Knob Dial (meter)   |
| 23.907-15                          | K11                 | 1                    | Knob Dial (7-1)   |
|                                    |                     | 1                    | #4 Hardware Envelope  |
|                                    |                     | 1                    | #6 Hardware Envelope  |
|                                    |                     | 1                    | #8 Hardware Envelope  |
|                                    |                     | 1                    | #10 Hardware Envelope                                       |
|                                    |                     | 1                    | 3/8" Hardware Envelope                                      |
|                                    |                     | 1                    | Terminal and Lug Hardware Envelope                          |
| 29.387                             |                     | 1                    | 15/32 I.D. x 59/64 O.D. Special<br>Washer                   |
| 13.49-9                            |                     | 6                    | Spacer 1/2" length x 3/8" O.D.<br>aluminum                  |
| 23.0802                            |                     | 1                    | Envelope Assembly for C30 cond-<br>enser                    |
| 133-278-7                          | S1,S2,S5,S70        | 4                    | 1 3/4" Miniature Tube Shield                                |
| 133-278-8                          | S6                  | 1                    | 2 1/4" Miniature Tube Shield                                |
| 17.755                             | S4A                 | 1                    | Oscillator Buffer Shield                                    |
| 17.756                             | S4B                 | 1                    | Oscillator Buffer Shield                                    |

|            |                                 |            |   |
|------------|---------------------------------|------------|---|
| 23.1003-3  | S5                              | 1          | Final Window Shield                                 |
| 23.1004-4  | S6                              | 1          | Meter Shield  |
| 17.814     | S7                              | 1          | VFO Socket Shield                                   |
| 120-277-1  | X1, X2, X5, X6<br>X11, X28, X70 | 7          | Shielded 7 pin Miniature Socket                     |
| 122-225    | X3, X4                          | 2          | 5 Pin Wafer Socket                                  |
| 122-228    | X8, X9, X10<br>X7, X17, X12     | 6          | Octal Wafer Socket                                  |
| 147-620    | X13A                            | 1          | 115 V Candelabra Socket                             |
| 147-600    | X14A                            | 1          | 6V Miniature Socket                                 |
| 147-310-56 | X13B                            | 1          | Faceted Jewel - red                                 |
| 147-310-57 | X14B                            | 1          | Faceted Jewel - green                               |
| 126-120    | X15                             | 1          | Crystal Mounting Board                              |
| 22.739-2   | X16                             | 1          | Fuse Extractor Post                                 |
| 22.740-5   | X18-19                          | 2          | "2005" Jones Terminal Strip                         |
| 22.740-6   | X20-22                          | 3          | "2006" Jones Terminal Strip                         |
| 22.740-3   | X23-27                          | 5          | "2003" Jones Terminal Strip                         |
| 71.32-170  | G1                              | 10 7/16"   | RG8U Cable (cut to length)                          |
| 71.32-178  | G2                              | 14"        | RG59U Cable (cut to length)                         |
| 22.741     | G3                              | 1          | Line cord and plug                                  |
| 22.113-1   | G4-10                           | 7          | Rubber Grommet 9/16 OD                              |
| 22.113-5   | G11-15                          | 5          | Rubber Grommet 11/32 OD                             |
| 22.840     | F1                              | 1          | 8 Amp 3AG Type or MTH Type 125-<br>250 Volt Fuse    |
| 42.24-77   | G16                             | 8"         | .034 ID Black Extruded plastic<br>tubing            |
| 42.24-107  | G17                             | 5"         | .133 ID Black extruded plastic<br>tubing            |
| 26.231     | W1                              | 1          | Wiring Harness                                      |
| 71.91-100  | W2                              | 13 1/2 ft. | Black Plastic covered #20 Hookup<br>wire            |
| 71.27-125  | W3                              | 7 ft.      | #24 Tinned Copper wire                              |
| 71.27-110  | W4                              | 4 ft.      | #14 tinned copper wire                              |
| 71.49-105  | W5                              | 1/2 ft.    | #20 Stranded Shielded Wire                          |
| 42.49-140  | W6                              | 6 ft.      | #4 Waxed Lacing Cord                                |
| 22.21      | I1                              | 1          | #6S6 120 volt candelabra bulb                       |
| 22.743     | I2                              | 1          | #40 6-8 volt Min. Screw Bulb                        |
| 119-852    | TC1-4                           | 4          | .360 Tube Cap                                       |
| 22.979     | J1                              | 1          | Mic. Connector                                      |
| 22.224     | J2                              | 1          | Ckt. Closing Jack                                   |
| 22.746     | J3-4                            | 2          | 83-1R Receptacles                                   |
| 126-105    | J5                              | 1          | Socket (crystal holder)                             |
| 23.1031    | J6                              | 1          | Plug relay connection                               |
| 105-520    | J70                             | 1          | Tip Jack, Red                                       |
| 22.747     | H1, H2                          | 2          | 83-1H Hood  |
| 23.914-1   | SH1-SH2                         | 2          | 100 M.V. Shunt for 500 ma.                          |
| 22.711     | SH3, SH4<br>R101                | 3          | 100 M.V. Shunt for 25 ma (5.1 ohm<br>5% tolerance)  |
| 22.712     | SH5                             | 1          | 100 M.V. Shunt for 50 ma (2.2 ohm<br>10% tolerance) |
| 22.748     | L1                              | 1          | 10 H 350 ma Filter choke SNC-P178                   |
| 22.749     | L2                              | 1          | 15 H 95 ma Filter choke SNC-P150                    |
| 22.750     | L3                              | 1          | 10 H 35 ma. Filter choke SNC-P170                   |
| 23.902-8   | L4                              | 1          | Oscillator coil                                     |
| 23.902-9   | L5A                             | 1          | Buffer Coil   |
| 23.913     | L5B                             | 1          | H.F. Buffer Coil                                    |
| 102-750    | L6                              | 1          | #750 R. F. Choke                                    |
| 102-754-2  | L7                              | 1          | #754 R. F. Choke                                    |

|           |                |    |   |
|-----------|----------------|----|---|
| 23.911    | L8             | 1  | Residual H. F. Final coil                     |
| 229-201   | L9             | 1  | Final Tuning Inductor, Variable               |
| 23.902-3  | L10, L70       | 2  | Auxiliary Coil                                |
| 23.912    | L11, L12       | 2  | Parasitic Suppressor                          |
| 23.1001   | L13            | 1  | Line Filter, VHF Choke Assembly               |
| 23.1000   | L14, L16, L19  |    |   |
|           | L20, L21       | 5  | VHF Filter Chokes                             |
| 23.1002-1 | L23            | 1  | Filament VHF Filter Choke                     |
| 22.751    | T1             | 1  | H.V. Plate transformer SNC #1781              |
| 22.753    | T2             | 1  | L.V. and Fil. Transformer SNC #1893           |
| 22.753    | T3             | 1  | Audio Driver Transformer SNC #1503            |
| 22.754    | T4             | 1  | Modulation Transformer SNC #1992              |
| 22.755    | SW1            | 1  | SPTS (6A-125V) Bat Handle Toggle switch       |
| 22.756    | SW2            | 1  | DPDT(6A-125V) Bat Handle Toggle switch        |
| 22.886    | SW3            | 1  | 4 Pole 2 Pos.(CW-PH) Switch                   |
| 22.1145-1 | SW4            | 1  | 2 Pole 9 Pos.(Band) Switch                    |
| 22.759    | SW5            | 1  | 1 Pole 7 Pos.(Coupling) Switch                |
| 22.760-2  | SW6            | 1  | 2 Pole 3 Pos(Auxiliary) Switch                |
| 22.761    | SW7            | 1  | 2 Pole 6 Pos.(Meter) Switch                   |
| 22.628    | SW8            | 1  | 1 Pole 11 Pos.(Crystal) Switch                |
| 167-104-3 | C22            | 1  | 75L15 Variable Condenser                      |
| 167-104-4 | C18            | 1  | 75L15 Variable Condenser                      |
| 154-2-3   | C29            | 1  | 350E20 Variable Condenser                     |
| 154-34-3  | C30            | 1  | 400E15 Variable Condenser                     |
| 22.763    | C1, C54        | 2  | 10 mfd. 25 V.W. Electrolytic cond             |
| 22.764    | C10, C11       | 1  | Dual 15-15 mfd 450 V.W. electrolytic cond.    |
| 22.765    | C12, C13       | 1  | Dual 15-15 mfd 150 V.W. electrolytic cond.    |
| 22.1010   | C71            | 1  | 150 mfd 150 V.D.C.W. electrolytic cond.       |
| 22.835    | C7             | 1  | .001 mfd 400 V.W. paper cond.                 |
| 22.766    | C2             | 1  | .003 mfd 400 V.W. paper cond.                 |
| 22.1006   | C3             | 1  | .5 mfd 400 V.W. paper cond.                   |
| 22.768    | C4, C56, C70   | 3  | .1 mfd 400 V.W. paper cond.                   |
| 22.769    | C8             | 1  | .5 mfd 600 V. W. paper cond.                  |
| 22.771    | C9             | 1  | 8 or 10 mfd 1000 V.W. cond.                   |
| 22.772    | C36, C37       | 2  | 300 mfd 600 V.W. Mica cond.                   |
| 22.773    | C14            | 1  | 50mmfd 500 V.W. molded mica cond.             |
| 22.774    | C33, C34, C35  |    |   |
|           | C52            | 4  | 300 mmfd 500 V.W. Molded mica cond            |
| 22.827    | C15-17, C19    |    |   |
|           | C21, C23 (2)   |    |   |
|           | C24, C26-27    |    |   |
|           | C39-44, C47-51 |    |   |
|           | C53, C72-73    | 24 | .005 mfd 600 V.W. ceramic disc cond.          |
| 22.776    | C20            | 1  | 50 mmfd 500 V.W. Silver mica cond.            |
| 22.777    | C25            | 2  | 25 mmfd 500 V.W. Silver mica cond.            |
| 22.778    | C38            | 1  | 150mmfd 1200 V. W. mica cond.                 |
| 22.828    | C28, C45       | 2  | .001 mfd 1500 V.W. ceramic disc cond.         |
| 22.836    | C31            | 1  | .002 mfd 1500 V.W. ceramic transmitting cond. |
| 22.826    | C32, C46, C55  | 3  | .01 mfd. 1500 V.W. ceramic disc cond.         |

|          |               |   |   |
|----------|---------------|---|---|
| 22.719   | R1            | 1 | 1 megohm-1/2 watt carbon or composition resistor          |
| 22.715   | R24           | 1 | 1800 ohm-1/2 watt carbon or composition resistor          |
| 22.868   | R2            | 1 | 150 ohm-1/2 watt carbon or composition resistor           |
| 22.967   | R32, R72      | 2 | 220,000-1/2 watt carbon or composition resistor           |
| 22.718   | R3, R29       | 2 | .47 - 0.51 megohm 1/2 watt carbon or composition resistor |
| 22.716   | R5, R26, R37  | 3 | 22,000 ohm - 1/2 watt resistor                            |
| 22.830   | R10, R11, R77 | 3 | 100 ohm 1/2 watt resistor                                 |
| 22.572   | R18, R73, R74 | 3 | 1 megohm 1/2 watt resistor                                |
| 22.713   | R22, R33, R34 | 3 | 22 ohm 1/2 watt carbon resistor                           |
| 22.717   | R23           | 1 | 47-51,000 ohm 1/2 watt resistor                           |
| 22.801   | R31           | 1 | 450 to 510 ohms 1/2 watt carbon or composition resistor   |
| 22.722   | R15           | 1 | 1500 ohm - 1 watt resistor                                |
| 22.721   | R16           | 1 | 820 ohm - 1 watt resistor                                 |
| 22.724   | R17           | 1 | 2700 ohm - 1 watt resistor                                |
| 22.853   | R19           | 1 | 68,000 ohm - 1 watt resistor                              |
| 22.720   | R20           | 1 | 100 ohm - 1 watt resistor                                 |
| 22.723   | R100          | 1 | 2000 ohm - 1 watt resistor(carbon)                        |
| 22.832   | R6, R30       | 2 | 1.0 megohm linear potentiometer                           |
| 22.732   | R25           | 1 | 25,000 ohm W.W. potentiometer                             |
| 22.729-1 | R13           | 1 | 20,000 ohm W.W. adjustable resistor                       |
| 22.833   | R28           | 1 | 20,000 ohm W.W. fixed resistor                            |
| 22.914   | R35           | 1 | 56 ohm 1 watt carbon or composition resistor              |
| 22.1004  | R70, 70B, 70C | 3 | 150,000 ohm 1 watt carbon resistor                        |
| 22.1005  | R71           | 1 | 390,000 ohm 1/2 watt carbon resistor                      |
| 22.728   | R75           | 1 | 220,000 ohm 1 watt carbon resistor                        |
| 22.1002  | R76           | 1 | 20,000 ohm potentiometer                                  |
| 22.1008  | RCT70         | 1 | 300 ma Selenium Rectifier                                 |
| 22.1009  | RCT71, 72     | 2 | 35 ma Selenium Rectifier                                  |
| 22.1011  | RLY70         | 1 | 10,000 ohm relay, DPDT                                    |
| 22.939   | M1            | 1 | 5 ma meter 20 ohm Special Scale                           |
| 22.780   | V1, V2, V6    | 3 | 6AU6 tube   |
| 22.783   | V3, V4        | 2 | 807 tube  |
| 22.781   | V5, V28       | 2 | 6AQ5 tube   |
| 22.738   | V7, V17       | 2 | 6146 tube   |
| 22.784   | V8, V9        | 2 | 5R4GY tube  |
| 22.791   | V10           | 1 | 5V4G tube   |
| 22.786   | V11           | 1 | 6AL5 tube   |
| 22.1007  | V70           | 1 | 6J6 tube  |

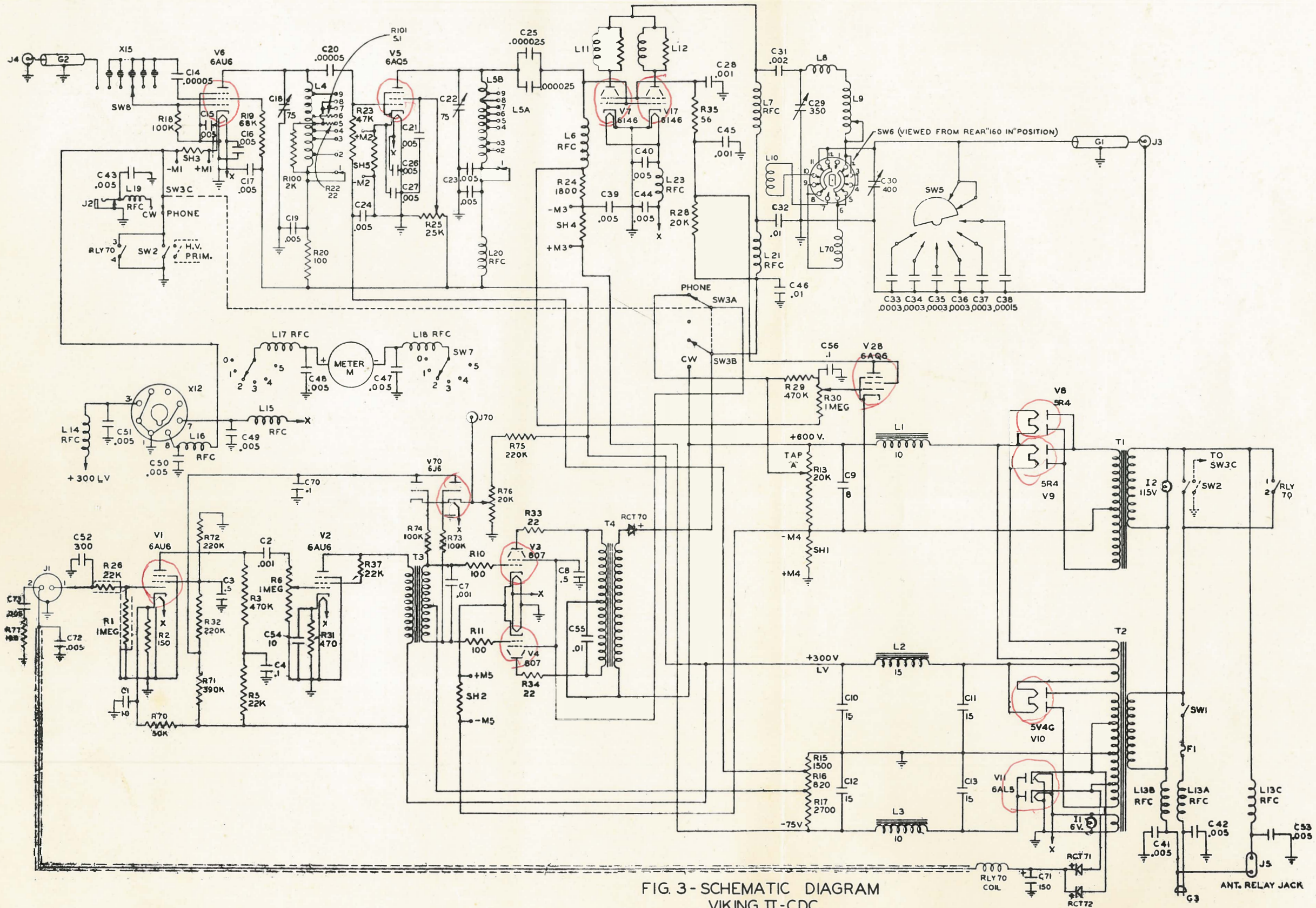
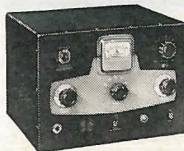
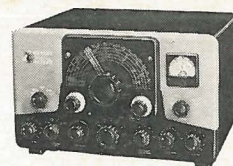

FIG. 3 - SCHEMATIC DIAGRAM VIKING II - CDC



**VIKING "ADVENTURER"**—50 watts CW input. Easy to assemble and operate—used to earn first novice WAC! Bandswitching 80, 40, 20, 15, 11 and 10 meters.



**VIKING "RANGER"**—75 watts CW input, 65 watts phone—a flexible, TVI suppressed transmitter . . . also serves as an RF and audio exciter without modification! Bandswitching 160, 80, 40, 20, 15, 11 and 10 meters.



**VIKING "VALIANT"**—275 watts CW and SSB, (P.E.P. input with auxiliary SSB exciter) . . . 200 watts phone. Built-in VFO—a transmitter with power and flexibility! As an exciter will drive any of the popular kilowatt level tubes. Bandswitching 160, 80, 40, 20, 15, 11 and 10 meters.

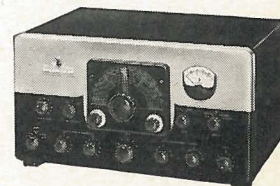

**VIKING "PACEMAKER"**—For Single Sideband—more than just an exciter. 90 watts CW and SSB (P.E.P.) . . . 35 watts AM. Rugged, stable VFO—"foolproof" voice control! Bandswitching 80, 40, 20, 15 and 10 meters.



# Johnson

## amateur equipment

**VIKING "FIVE HUNDRED"**—600 watts CW input . . . 500 watts AM and SSB. (P.E.P. input with auxiliary SSB exciter.) VFO and all exciter stages gang-tuned! Bandswitching 80, 40, 20, 15, 11 and 10 meters.



**VIKING "6N2"**—For VHF! 150 watts CW input . . . 100 watts AM. Rugged construction, thorough engineering—the same Johnson quality for 6 and 2 meters!

**AUDIO AMPLIFIER**—Self contained 10 watt speech amplifier complete with power supply. Speech clipping and filtering designed to raise average modulated carrier level . . . improves the performance and effectiveness of your AM transmitter!

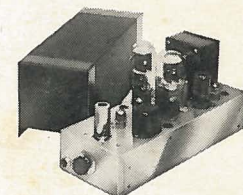

**VIKING "MOBILE"**—Rugged 60 watt mobile transmitter with an enviable DX record—under-dash mounting—convenient to operate! Bandswitching 75, 40, 20, 15, 11 and 10 meters.

**VIKING "KILOWATT"**—Boldly styled kilowatt power amplifier. 1,000 watts CW, AM and SSB—the ultimate in styling and operating convenience. Continuous tuning 3.5 to 30 megacycles.

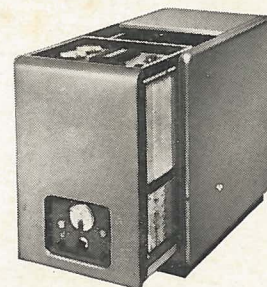

**KEYS AND PRACTICE SETS**—Johnson also makes a complete line of semi-automatic, high speed, standard, heavy duty and practice keys. See your distributor or write for complete information.



**E. F. Johnson Company**

W A S E C A , M I N N E S O T A